



hanla@raycontrol.com | +65 88103634 | +65 88491139

Cargo Tank Measuring System

MONITORING AND ALARM SYSTEMS



Production & Sales Items

- RADAR BEAM TYPE CARGO MONITORING SYSTEM
 - FMCW TYPE
 - PULS RADAR TYPE
- MAGNETIC FLOAT TYPE CARGO MONITORING SYSTEM
- INDEPENDENT HIGH AND OVERFILL ALARM SYSTEM
 - MAGNETIC FLOAT TYPE
 - ACOUSTIC WAVE TYPE
- VAPOUR EMISSION CONTROL SYSTEM
- VAPOUR PRESSURE MONITORING SYSTEM
- FIXED GAS SAMPLING SYSTEM
- TANK REMOTE SOUNDING SYSTEM
 - AIR PURGE TYPE
 - ELECTRIC PRESSURE TYPE
- WATER INGRESS DETECTION SYSTEM
 - ELECTRIC PRESSURE TYPE



Head Office & Factory
1610-5, JONGGANGDONG GANWON-DO, BUSAN, KOREA
TEL: 051-51401-2000 FAX: 051-51401-1000
http://www.hanla-ims.com e-mail:hanla@hanla-ims.com

China Office & Factory
HANLA MARINE MACHINERY & ELECTRIC CO., LTD.
CHINA YULIENG ROAD #1 GUSTAI ROAD
ZHANGJIANG CITY JIANGSU 215000 CHINA
TEL: 0512-52570-2001 FAX: 0512-52570-2002
E-mail:hanla@hanla-ims.com



Company History

HANLA IMS, was found in 1982 as a manufacture to make a top-leading company in the field of instrumentation for level control and measuring under the company motto of customer satisfaction, quality assurance, maintenance of the quality in the world. Since that time, we have been continuously making every possible effort to develop a wide variety of instrumentation such as level gauges, level switches and level transmitters, to meet diversified demands of our customer. As a result of the continuous effort, we were registered as a sub-supplier for biggest domestic shipyards, and could stand firm our position as a top leader in the field of marine by acquiring the type approval certificate for our product through the classification society since 1987.

In the 1982, we signed technical license with Award in France which is a leader company in the field of instrument in the world, so do to diversify and improve our own product.

Between 1987 and 1995, we acquired the quality authorization certificate which can supply our own instrumentations to the thermal power plant and nuclear electric power plant from Korea Electric power corporation on the basis of high quality assurance program to expand our level market at we more and more.

We acquired the quality assurance system certificate conforming to Quality system standard ISO 9001 by DNV certification B.V to keep excellent quality and since in the November 13th, 1997 as well as CE mark for cargo monitoring system, air purge type remote sounding system and all kind of level switch in 31 march 2000. HANLA Co., Ltd. will do our best to be a best professional company and a leader in the world under our motto of customer satisfaction, quality assurance, maintenance of the quality, and business rationalization, unity & harmony among men.

On November, 1st, 2008, we are pleased announcing the new CI of HANLA IMS by launching Valve Remote Control System, Deck Machinery, Loading Computer as well as Level Measuring System. We know you will want to take advantage, and we will support all the of customers in the world. Expand your mind on the new HANLA IMS!

Many thanks and wish for your health!



Manufacturing Line Authorized by the Quality

HANLA IMS Co., Ltd.

We manufacture the first class product in the world with optimum design from research & development, customer production system, customer-friendly quality control system.



Contents



Cargo Tank Measuring System

- 04. TANK REMOTE SOUNDING SYSTEM
- 05. TANK REMOTE SOUNDING SYSTEM
- 06. CARGO MONITORING SYSTEM
- 07. INDEPENDENT TYPE TANK HIGH LEVEL ALARM SYSTEM
- 08. INDEPENDENT TYPE TANK HIGH LEVEL ALARM SYSTEM
- 09. WALKER INJECTION CONTROL SYSTEM
- 10. THE FROD GAS SAMPLING SYSTEM
- 11. WALKER PRESSURE MONITORING SYSTEM



Tank Remote Sounding System

- 20. TANK LEVEL MONITORING SYSTEM
- 21. TANK LEVEL MONITORING SYSTEM
- 24. MICROPROCESSOR CONTROLLED ELECTRO-PNEUMATIC LEVEL MONITORING SYSTEM
- 25. TANK LEVEL MONITORING SYSTEM
- 26. ELECTRIC PRESSURE TYPE TANK REMOTE SOUNDING SYSTEM



Water Ingress Detection System

- 30. WATER INGRESS DETECTION SYSTEM



Cargo Tank Measuring System



ADVANTAGES

- Stand alone microprocessor based transmitter
- Dedicated algorithms
- Still pipe or free space mode
- Integrated temperature and pressure measurements
- Approved by major classification societies

FEATURES

- .Automatic antenna fouling detection
- .Automatic radar self-test during power up
- .Materials : 316Housing / Teflon radome
- Ø200 flat antenna type

GENERAL

The 8" EM540 radar is especially designed be integrated cargo monitoring system for inland river or ocean going vessels and tank barge. The EM540 radar is based on the utilisation of smart sensors, icluding microprocessors performing signal processing and offer, in addition to transmitting tank level, pressure, and temperature data to the central monitoring system, capabilities suh as self-diagnostics, self-monitoring and remote configuring. These capabilties allow for predictive maintenance owing to the

continous tracking of performance drift. The radar measurement head features a very compact design due to its wide band printed circuit planar antenna. Finally, the use of an intrinsially safe two-way digital signal transmission, between the radar and the central monitoring system, provides for a ready integration of EM540 radar to any type of control system.

TECHNICAL DATA

- Accuracy : +/-1mm
- Protocol : Modbus(RTU)
- Operaating temperature : -35 °C to +70 °C
- Storage temperature : -40 °C to +85 °C
- Range : -0.6 to +40n

- Intrinsic safety approval : I I1/2G EEx ia I I B T4
- Protection class : IP66/67
- Anntena aperture angle : 13°
- FMCW-10GHz Radar

INERT GAS PRESSURE TRANSMITTER T901-P 01TA



DESCRIPTION

The pressure transmitter T901-P01A is especially designed to meet liquid cargo monitoring requirements.

TECHNICAL DATA

- 3-wire absolute transmitter
- Range : 800-2000mbar
- Accuracy : 1% of measured scale
- Output : 0.5 to 2.5VDC
- Allowable overpressure : 4000m bar
- Power supply : 5VDC
- Intrinsically safe : EEx ia I I C T6
- Storage temperature : -55 °C to +85 °C
- Connecting unit operating temperature : -20 °C to +70 °C
- Protection class : IP67

TEMPERATURE TRANSMITTER T901-PxOPI

CARGO PUMP MOUNTING TYPE

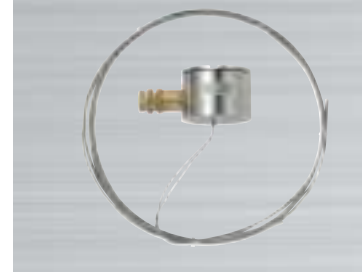

DECK MOUNTING TYPE



DESCRIPTION

The temperature transmitter T901-PxOPI is specially designed to meet liquid cargo monitoring requirements.

TECHNICAL DATA

- Temperature senson : 3-wires 100ohm at 0 °C
- Accuracy : IEC 751 classB
- Protection class : IP67
- Rang : -20 °C to +120 °C(other scales on request)
- Intrinsically safe : EEx ia I I C T6
- Storage temperature: -55 °C to +85 °C
- Connecting unit operating temperature : -20 °C to +70 °C

SAFETY UNIT (TA3840S)



DESCRIPTION

TA3840S safety unit consists of a 19" rack into which the radar power supply boards are inserted. Each rack has 8 available slots(one slot for two radars)and the maximum cofiguration is 4 racks(power supply of 64 radars). The radar level transmitters are configured directy on each power supply board via RS232 port. .Operating temperature : 5 °C to +70 °C .Power supply : 115 or 230VAC/50-60Hz .Consumption : 100AC max. per rack

TECHNICAL DATA

- Intrinsicall safety I I (1)G [EEx ja] I I B
- I/O port : RS232 on front face of power supply board
- Transmitter connection number : 16 max.
- Temical capacity : 2.5m m³

COMMUNICATION UNIT (TA3840C)



DESCRIPTION

TA3840C Communication Unit connects four ports of communication with radar level transmitters. These ports arre indendent one of the others, they use the protocol Modbus RTU. The TA3840C also allows th display the parameters as cargo level, tempeature, IG Pressure. The TA3840C is installed in a 19" rack with a display unit with a LCD screen for measurement and alarm display.

TECHNICAL DATA

- Power supply : 24VDC
- Max. radar : up to 96(analog board)
- Combined board : 4..20mA : up to8 binary in : up to 16, binary in : up to 24
- Comuication : 3RS232, RS485 or RS422 ports 1RS232, RS485 ports 1RS485, TTL extension port
- .Monitoring : 2 alarm thresholds per channel
- .Operating temperature : 0 °C to +70 °C
- .Protocol. Modbus. RTU

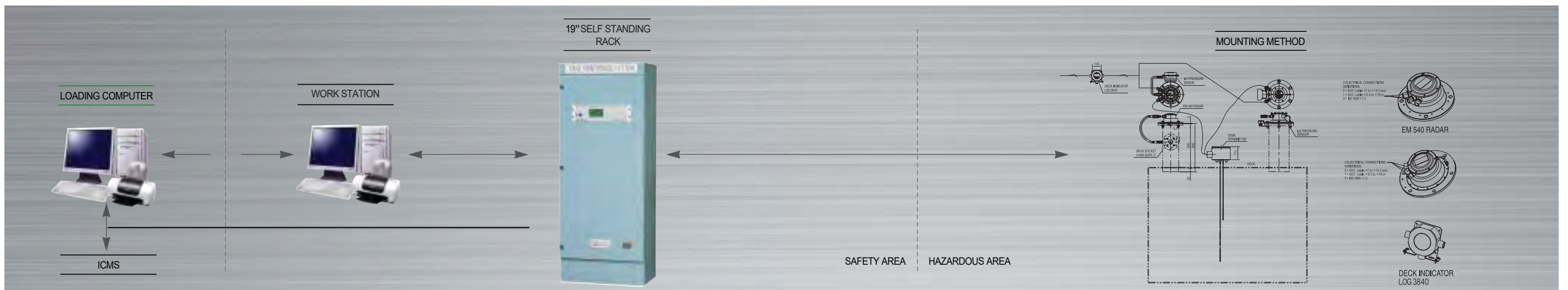

Cargo Tank Measuring System



APPRICATIONS

Two different emitting frequencies are available for these applications, the compact, high frequency sensors are particularly suitable for applications for which high accuracy is reached. Low frequency C band sensors can penetrate foam and strong condensation and are thus particularly suitable for arduous process conditions. Unaffected by steam, gas composition, pressure and temperature changes the sensors detect the product surface of different products reliably.

FEATURES

- Small housing and small protection collection
- Low cost with high quality
- Two-wire technology loop powered
- Accurate and rugged design
- Adjustment choice

GENERAL

Extremely short microwave impulses are emitted by the antenna system to the measured product, reflected by the product surface and received again by the antenna system. They spread with high velocity and the time from emission to reception of the signals is proportional to the level in the vessel. A special time spreading procedure enables the reliable and precise measurement if the extremely short times.

The radar sensors work with low emitted power in the C and K-band frequency range. The proven ECHOFOX signal processing selects the correct level echo reliably from a number of false reflections. An adjustment with empty and full vessel is not necessary.

STANDARD MODEL AND SPECIFICATION

Model						
	PULS61	PULS 62	PULS 63	PULS 65	PULS 66	PULS 68
Application	aggressive liquids in small vessels under easy process conditions	storage and process vessels under arduous process conditions	aggressive liquids under arduous process conditions	aggressive liquids under easy process conditions	storage and process vessels under arduous process conditions	large solid vessels under arduous process conditions
Measuring range	up to 20m	up to 35m	up to 20m	up to 35m	up to 35m	up to 70m
Process temperature	-40..80°C	-40..200°C	-40..150°C	-40..150°C	-40..500°C	-40..200°C
Process pressure	-1..3bar	-1..40bar	-1..16bar	-1..16bar	-1..160bar	-1..40bar
Accuracy	±5mm	±3mm	±3mm	±10mm	±10mm	±15mm

COMMUNICATION AND SAFETY UNIT



SPECIFICATIONS

- Power Supply : 24VDC
- Cargo Tank : Up to 24 (Radar)
- Ballast & Other Tank : Up to 31
- Communication : 1 X RS232 / 485 / 422 (Input)
3 X RS232 / 485 / 422 (Output)
- Relay output : 4 X NO / NC
- Protocol : Modbus RTU
- Operating temperature : 0-60°C

TEMP. & PRESS. TRANSMITTER



SPECIFICATION FOR I.G PRESSURE TRANSMITTER

MODEL : TLP100S
RANGE : 800-2000mbar
ACCURACY : ±0.2%
EEX ia IIB T4
FOR I.G PRESSURE

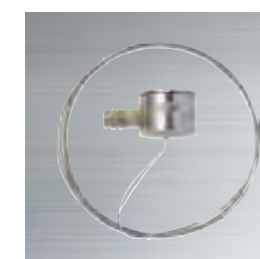

SPECIFICATION FOR TEMPERATURE TRANSMITTER

MODEL : TLP100S
ACCURAY : ±0.3Deg.°C
ACCURACY : -20-80°C
EEX ia IIB T4
PT 1000 RTD
MAX. 3 POINTS OF TEMP.

DECK MOUNTING METHOD FOR RADAR, TEMPERATURE AND PRESSURE SENSOR

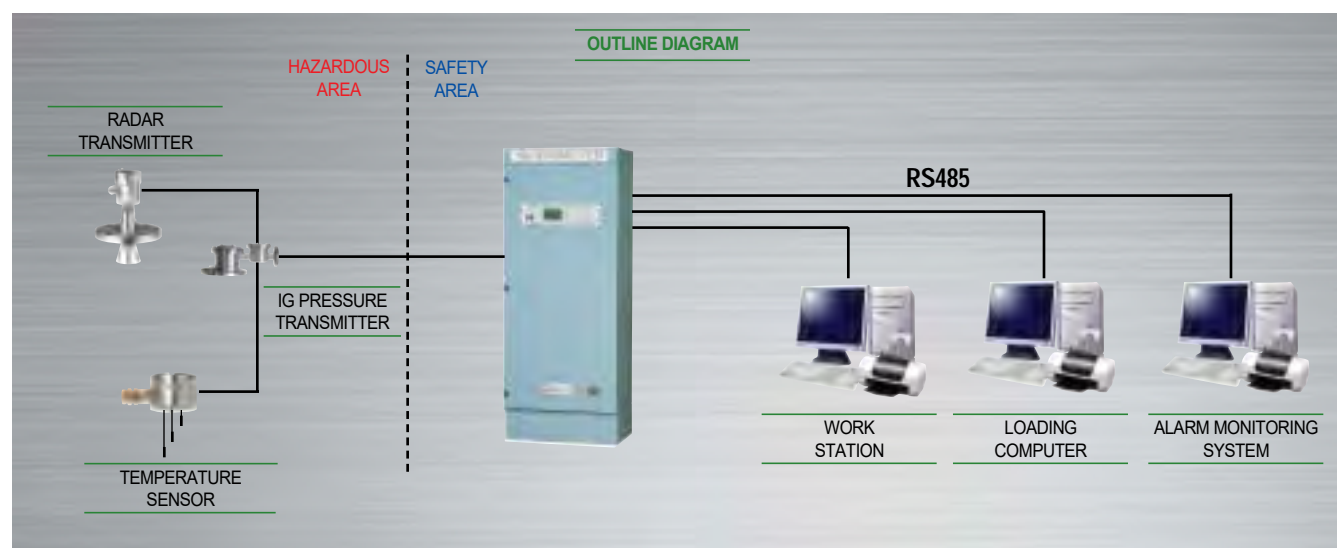
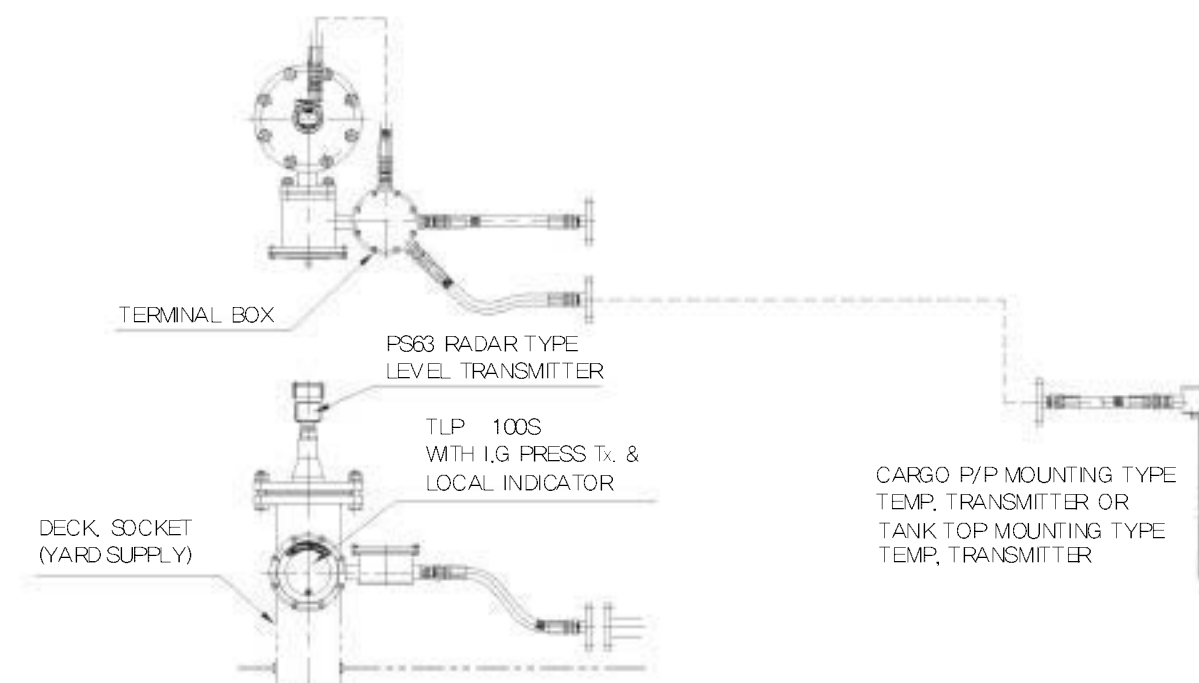

Cargo Tank Measuring System

GENERAL

The TLP-100, LIQUID LEVEL is the newest version of magnetic float level gauge for marine tankers which has been developed based on the long time field experience. The detection of float position is conducted by Hall IC elements to eliminate problem of contact fusing and/or accuracy failure caused by existing reed switch system.

By this remarkable sensing system, long time stability and maintenance free operation have been achieved.

The measurement is free from the conductivity and/or dielectric constant of the cargo liquids.

Thus TLP-100 is widely suitable for measurement and control of cargo liquid levels at crude oil carriers, coaster tankers, product carriers chemical carrier, etc.

SYSTEM CONSTRUCTION

System	Model	CARGO MONITORING SYSTEM (TLP-100)
DESCRIPTION		INTRINSICALLY SAFE LEVEL TEMP. AND PRESSURE MONITORING SYSTEM
LEVEL SENSOR		LOCAL GAUGE TLP-100S
SAFETY BARRIER		TLP-100B
MAIN CONTROL PANEL		<ul style="list-style-type: none"> MULTI-TANK MONITOR TLP-100D (TOUCH SCREEN COMPUTER) TLP-100MUX

FEATURES

- Compact and cost saving design.
- Hall IC Elements, pure electric position detection:
 - Grade up from existing reed switch system.
 - Highly reliable and stable for long time operation.
 - Highly precision for operation.
- 3 Point of temp. measurement and transmission.
- Separatable LCD indicator.
 - LCD indicator may be separated from the sensor.
- 2 Core cable data transmission and easy wiring:
 - Liquid level and maximum 3point temp. data are sent to CCR by serial BCD signal through 2 core cable only including power supply to the deck.
- Full line up of CCR indication system
 - Full line up from individual indicator to computer based system is ready to meet for requirements.

BLOCK DIAGRAM

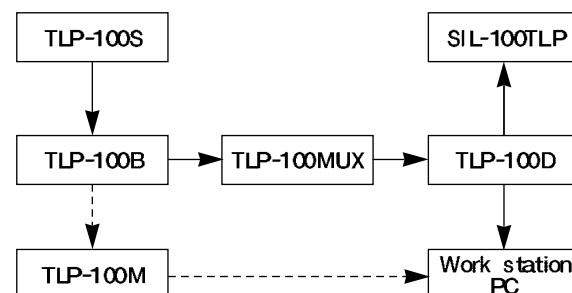

APPLICATION

This system is for monitoring for level, alarm and temperature of the liquid in cargo tanks.



LOCAL GAUGE : TLP-100S

SPECIFICATION

- **Detection unit** : Level : by magnetic float and Hall IC element
Temp : by PT-100RTD
Pressure : ceramic sensor
- **Accuracy** : Level : every 10mm (standard)
: every 5mm (option)
Temp : ±1.0 °C
- **Measuring range** : Level : max. 20M
Temp : -25 °C ~ +125 °C
Pressure : 900 ~ 1300mBar
- **Indication** : By selector type LCD 6 digit indication
1) Level : 5mm unit (0- 20.000 M)
2) Temp. (U : Upper) °C or °F unit
(M : Middle) °C or °F unit
(L : Lower) °C or °F unit
- **Output** : Digital serial code pulse (2 wire system including power supply, exclusive receiving unit is required)

MULTI-TANK MONITOR : TLP-100D

The cargo monitoring panel will be designed and arranged for level alarm, high temp. alarm, and temp. level measurement based on the number of tanks and tank location etc..

The cargo tank monitoring panel gives audible and visible alarm as well as cargo tank level, temp. indication on the mimic board, and also external alarm for high an high-high level shall be provided by cargo monitoring panel.

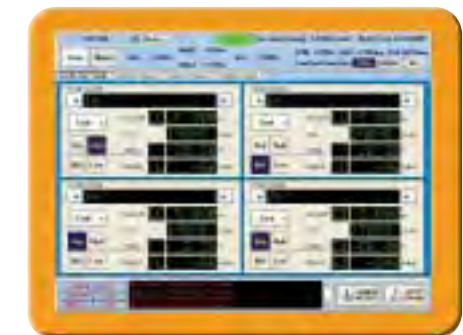

INDICATOR : SIL-100TLP



SPECIFICATION

- **Indication** : Individual tank LCD indicator
- Tank selector and temp. element selector keys are provided.
- **Level** : 0 ~ 20.000M a
(ullage or sounding selectable)
- **Level status** : 2 digits
- **Alarm setting and monitoring** :
 - 1) 4 level alarms(HH, H, L, LL) for 24 tanks
 - 2) 2 temp. alarms(H, L) for each element of tanks (U, M, L)
 - 3) 4 Pressure alarm(HH, H, L, LL) for 24 tanks
- **Input** : RS485 port for indicator (MODBUS PROTOCOL)
- **Common or Individual Indicator**

SELECTED TANK

Easy Operation by the Touch screen.

TOTAL TANKS

Mimic diagram display Of Total tanks information.

DETAIL TANK

Calculation of Level, Pressure, Volumes and Average Temperature.

TRENDS CURVE

Saving of Tank loading, Discharging information.

SPECIFICATION

- **Indication** : 10.4" Touch screen LCD
- **Serial Port** : Two RS232 and selectable RS232 / 422 / 485 serial ports
- **Built-in multiplexer Board TLP-100MUX** :
 - Input : 8 Port 4 ~ 20mA
 - 24 Tank sensor(Level,Temp.Pressure)
 - Output : 13 Relay Contact
 - RS485 or RS232 COMMUNICATION (MODBUS PROTOCOL)

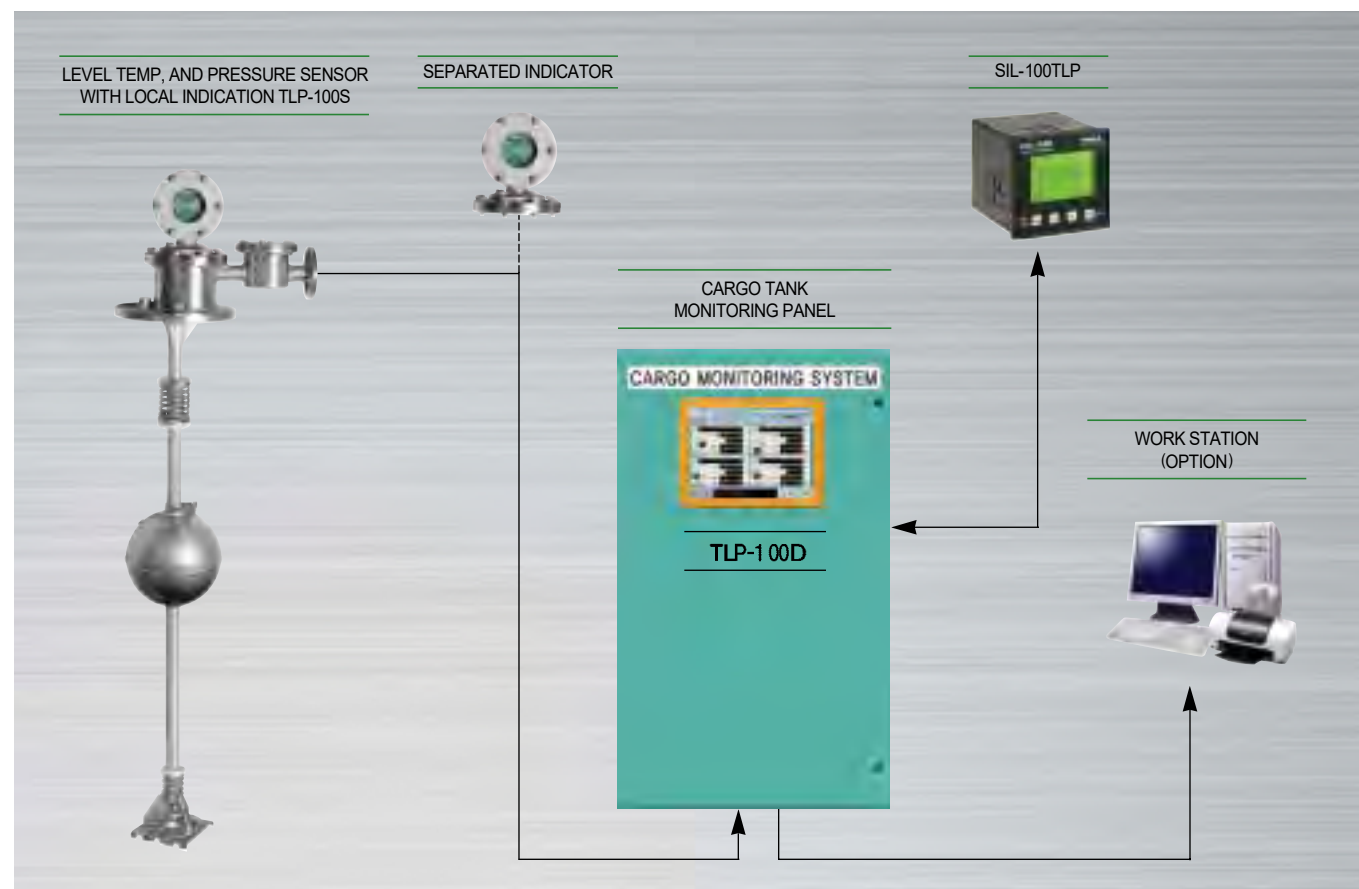

Cargo Tank Measuring System

HANLA's cargo tank high/overflow alarm system is thoroughly designed according to USCG latest requirements, and are to be required by IBC code.

GENERAL

This alarm system consists of level alarm sensor, I.S barrier and alarm panel. When the liquid level reaches a set point, the reed switch in the alarm sensor is actuated by magnetic float. This signal is connected to alarm annunciator through safety barrier. At the same time, we can get audible and visible alarm on the main alarm panel as well as external alarm on the bridge top. The 95% of volume is normally for high alarm and 98% of volume is normally for overflow alarm.

FEATURES

- Most advanced electric technology for high reliability and durability.
- Certified by major certifying authorities.
- Designed for all kind of liquid.
- Simple for construction.
- Intrinsically safe designed unit is applicable to all kind of inflammable fluids.
- Lifting type manual test device which can check the function.

APPLICATION

These systems are used for the level alarm in cargo tanks of all kind of oil and chemical carriers.

TECHNICAL SPECIFICATION

ALARM SENSOR

- **Model :** High alarm:TMR-701T
High and overflow alarm:TMR-702T
- **Conn. size :** JIS 5K 100A(standard)
- **Conduit conn. size :** JIS 5K 32A(standard)
- **Material :** - Housing - SUS304
Flange - SUS304 or SUS316
Guide pipe - SUS316
Magnetic float - SUS316
- **Contact form/rating :** SPST/250VAC, 0.5A
- **Accuracy :** ±5mm on level rise or fall
- **Specific gravity :** 0.65-1.5
- **Max. working temp :** -25-+100°C
- **Alarm point :** 95% of volume for high level alarm
98% of volume for overflow alarm
- **Protection :** IP56 over
- **Safety :** EEx ia IIC T6

LEVEL ALARM PANEL

- **Power supply :** AC 110/220V(Main)
DC 24V(Back up)
- **Consist of :** - Alarm annunciator - I.S Barrier
- Power lamp - DC power fail alarm
- Alarm buzzer
- **External alarm :** Horn & Light

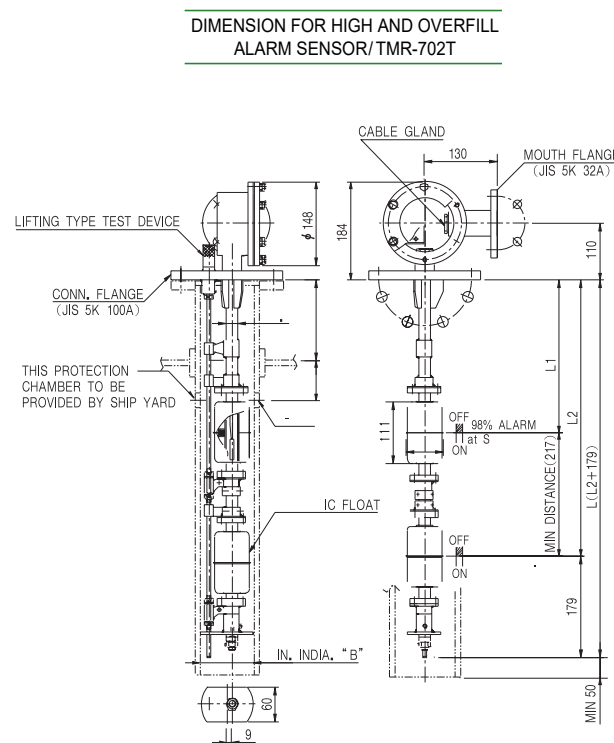
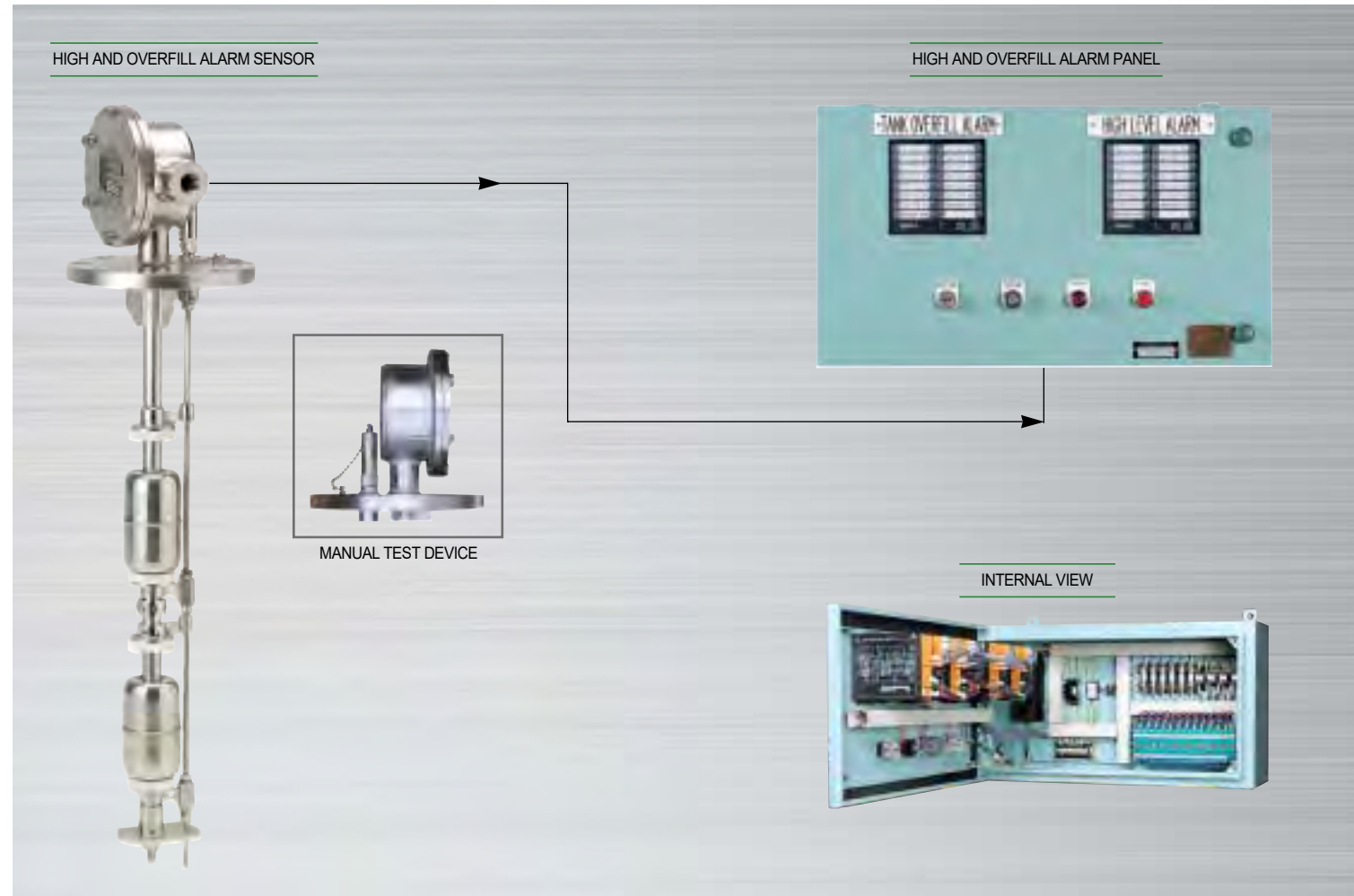

ONE LINE BLOCK DIAGRAM FOR HIGH AND OVERFILL ALARM SYSTEM

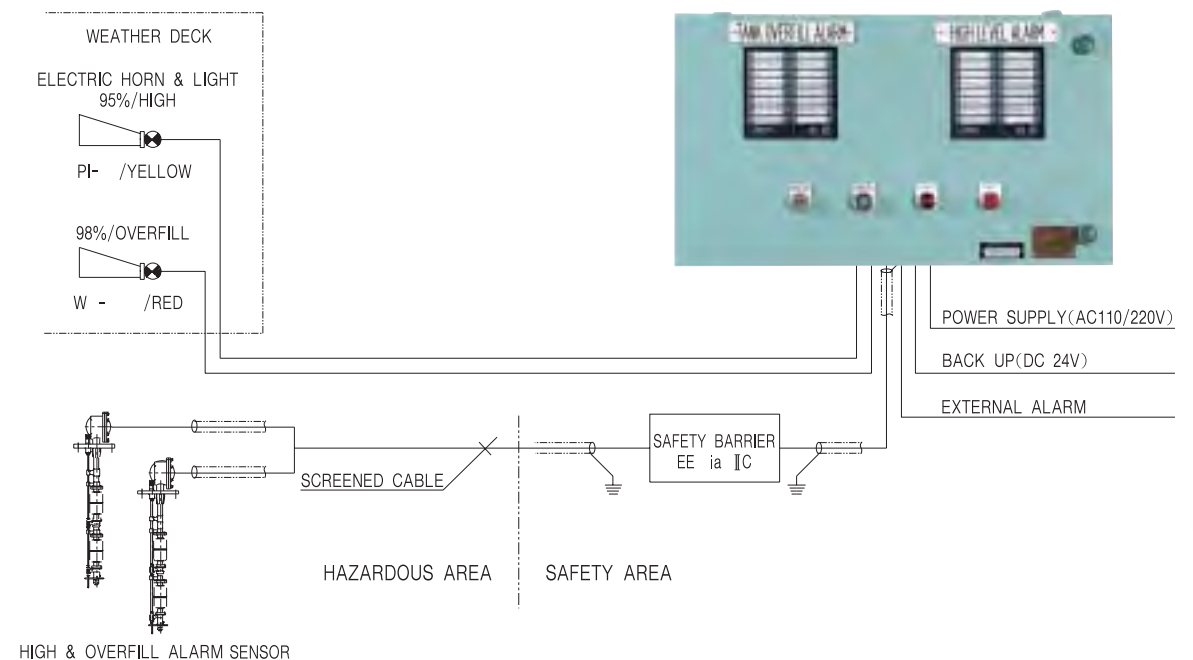

ALARM MODULE



- Channel number : 16 contacts.
- Alarm Input time delay : 0-99 sec.
- Alarm escape time delay : 0-99 sec.
- Channel outputs : NC or NO.
- Common relay output.
- Internal Buzzer.
- Buzzer Stop button.
- Flicker Stop button.
- Supply voltage : 24 VDC (18-32 VDC).
100-240VAC (option).
- Indication LEDs : 16 × red/green, 1 × yellow, 1 × green
- First alarm flashing.
- Serial Communication : RS-485.
- Channel setting : by internal rotary switch.
by windows setting program.
- Power consumption : Max. 4.5 Watt at 24 VDC.
- Operating temperature : -10°C to +55°C (70°C peak).
- Alarm module enclosure : standard DIN 144 × 144 × 86 mm.
- Type code selection : AU-160D-AB.
A : Channel Output.
0 : None.
1 : Isolated Output.
B : Power.
0 : 24VDC.
1 : 100-240VAC
- AU-160D : High Level Alarm, Overflow Alarm application.
Inhibit buttons for each channel.
Navigation function.
- AU-160D(W) : Water Ingress Detection System application.
Overriding buttons for Pre-alarm and Main-alarm.
- Optional repeater unit : AU-160R by RS-485.

Cargo Tank Measuring System

HANLA's cargo tank level alarm system is thoroughly designed according to IMO'S latest rule requirements, and are to be required by IBC code.

GENERAL

Acoustic wave type LIDEC-L91/92 local sensor is specially designed and patented for the marine applications. The series LIDEC L91/92 offers a reliable solution for high level and high-high level(overflow)alarm detection of chemical, FO, DO tank, etc. The principle of this fully static system is based on the propagation of an acoustic wave inside a metallic probe.

A piezo-electric sensing element produces the wave along the probe. Without liquid, waves propagate without attenuation inside the metal of probe. Subject waves are detected by a receptor which converts them into an electrical signal, re-injected on the emitter, the gain being adjusted in order to obtain a permanent oscillation on the loop.

As the liquid reaches the end of probe, a portion of the waves is absorbed, the oscillation stops and the alarm is activated.

As the liquid reaches the end of probe, a portion of the waves is absorbed, the oscillation stops and the alarm is activated.

SYSTEM CONFIGURATION

For the total system, safety barrier, alarm unit(as a converter current to on-off signal)and annunciator are connected with local sensor LIDEC-L91/92.

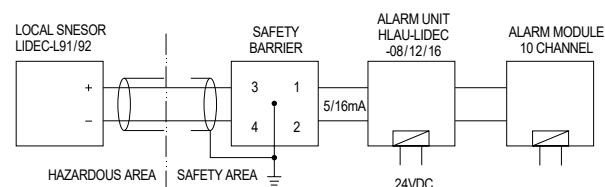

FEATURES

- Designed for solution of safe construction which the probe does not work as electrode for sparks between comming up liquid surface and highly voltage charged by electro-statics during cargo loading.
- Fully static system with no moving parts.
- No special calibration depending on the liquid.
- Vibration, shock and electric interferences resistant.
- Pressure and temperature resistance.
- Designed for all kind of liquid.
- Including fail safe system.
- Manual test device : Prior to loading or any time, the level alarm can easily be tested by using a testing tool with permanent magnet.

APPLICATION

These systems are used for the level alarm in cargo tanks of all kind of oil/chemical carriers.

STANDARD MODEL AND APPLICATION

- LIDEC - L91 : High level or overflow alarm.
- LIDEC - L92 : High level and overflow alarm.

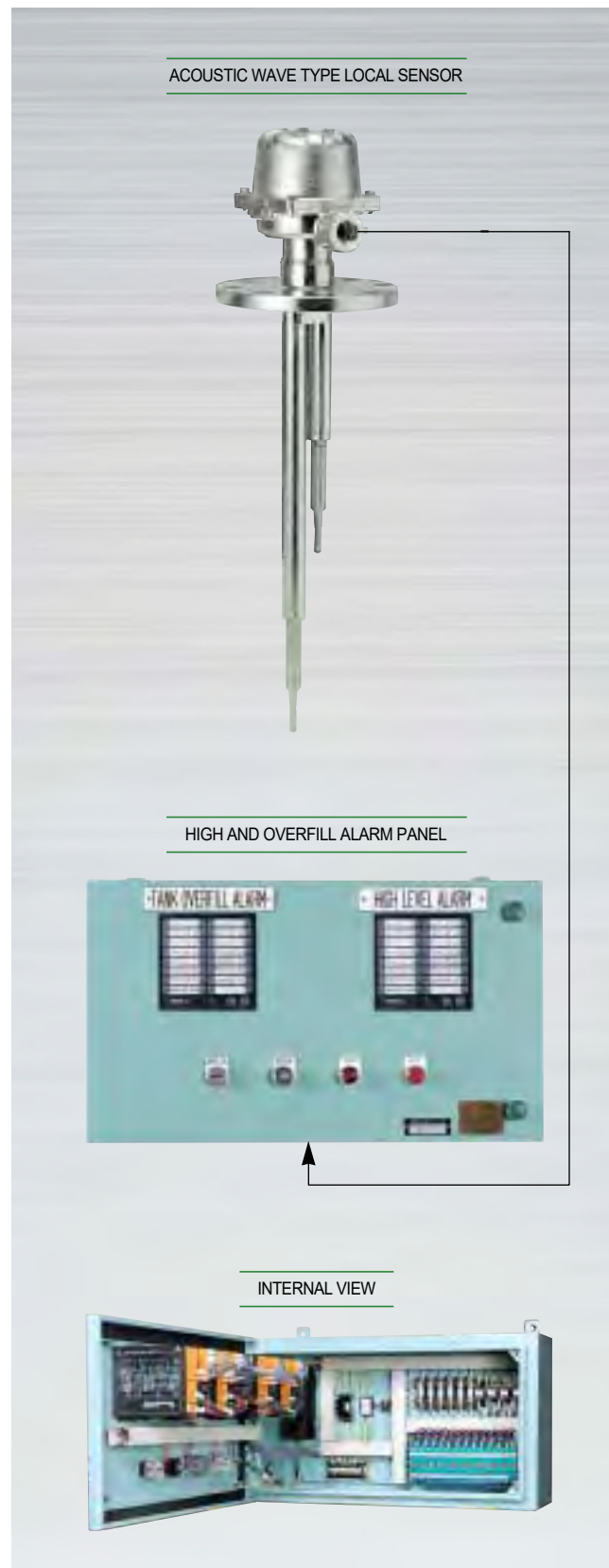

SYSTEM SELECTION FOR ORDER CONFORMATION

- CMS - LIDEC - □
- L91 : HIGH LEVEL OR OVERFILL ALARM SYSTEM
 - L92 : HIGH LEVEL AND OVERFILL ALARM SYSTEM

TECHNICAL SPECIFICATION

ALARM SENSOR

- Model : High alarm:LIDEC-L91
High and overflow alarm:LIDEC-L92
- Conn. size : JIS 5K 100A(standard)
- Conduit conn. size : JIS 5K 32A(standard)
- Material : - Housing - SCS13
- Flange - SUS304 or SUS316
- Sensor Probe - SUS316L
- Power supply : 18 to 28VDC
- Output : 4 .. 20mA current loop with
6mA No alarm
18mA Alarm
- Operating Temp. : AMB- -25°C to 70°C
LIQUID- -40°C to 150°C
- Protection : IP56 over
- Safety : EEx ia IIC T6

LEVEL ALARM PANEL

- Mounting type : Wall mounting or console mouning
- Power supply : AC 110/220V(Main)
DC 24V(Back up)
- Consist of : - Alarm annunciator/10ch
- Alarm unit for lidec sensor
- Safety barrier
- Power lamp
- AC and DC power fail alarm
- Alarm buzzer
- External alarm : Horn & Light

CARGO TANK LEVEL ALARM PANEL

- The cargo tank level alarm panel will be designed and arranged for level alarm based on the number of tanks and tank location etc. The cargo tank level alarm panel gives audible and visible alarm and also external alarm will be provided.
- The individual external alarm will be provided in accordance with owner requirement as optional items.

ALARM MODULE



- Channel number : 16 contacts.
- Alarm Input time delay : 0-99 sec.
- Alarm escape time delay : 0-99 sec.
- Channel outputs : NC or NO.
- Common relay output.
- Internal Buzzer.
- Buzzer Stop button.
- Flicker Stop button.
- Supply voltage : 24VDC(18-32VDC).
100-240VAC(option).
- Indication LEDs : 16 x red/green, 1 x yellow, 1 x green
- First alarm flashing.
- Serial Communication : RS-485.
- Channel setting : by internal rotary switch.
by windows setting program.
- Power consumption : Max. 4.5 Watt at 24VDC.
- Operating temperature : -10°C to +55°C (70°C peak).
- Alarm module enclosure : standard DIN 144 x 144 x 86 mm.
- Type code selection : AU-160D-AB.
A : Channel Output.
0 : None.
1 : Isolated Output.
B : Power.
0 : 24VDC.
1 : 100-240VAC
- AU-160D : High Level Alarm, Overflow Alarm application.
Inhibit buttons for each channel.
Navigation function
- AU-160D(W) : Water Ingress Detection System application.
Overriding buttons for Pre-alarm and Main-alarm.
- Optional repeater unit : AU-160R by RS-485.

DIMENSION FOR LOCAL SENSOR LIDEC-L92

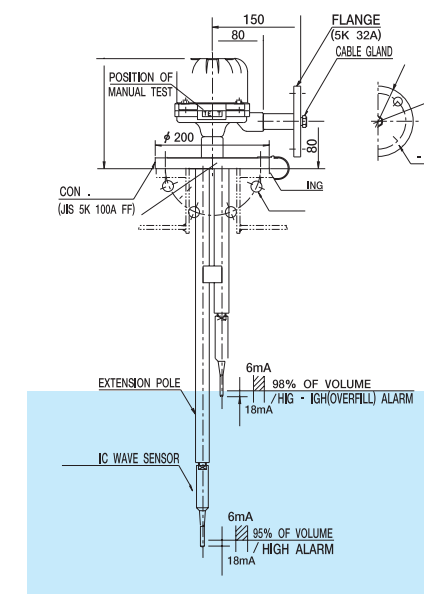

Cargo Tank Measuring System

GENERAL

Vapour emission control system is intended for analyzing the waste vapour gas for oxygen gas content. The system also includes the pressure transmitter which can monitor the pressure on the waste vapour line. This system consists of two cabinets ; a detector cabinet in which the pressure transmitter, oxygen sensor, flow alarm sensor, sample selector valve and purge valve are included, and the monitoring & alarm panel on which the alarm unit, oxygen indicator are provided. The detector panel in steel is installed on deck nearby the vapour manifolds and the monitoring & alarm panel is mounted in the cargo control room.

PRINCIPLE OF OPERATION

The sample tubes in the detector cabinet run from the sample point inlets to oxygen sampling selector valve and mode selector valve. Exiting from this single tube is leading the chosen sample gas through filter between oxygen sampling selector valve and mode selector valve, and then finally passes the oxygen sensor, exhausted through the exhausting line on the cabinet panel. The display shows the O2 concentration from 0.0 to 25.0V% O2 on the oxygen monitor and the "High oxygen content alarm" is activated at 8V% O2. The "Flow failure" is also operated when the flow is stopped. The display shows the pressure transmitted from waste vapour line on the vapour pressure indicator from 0 to 200mbar. The "Low pressure alarm" is also activated at 10mbar and the "High pressure alarm" ;at 120mbar. It is possible to increase or decrease the pressure alarm value freely and the external alarm output relay for all alarm can be provided as optional items.

FEATURES

- Intrinsically safe detecting is applicable to all of inflammable fluids
- All stainless steel material pressure sensor
- Individual adjustable alarm for oxygen and pressure
- Most advanced electronic technology for high reliability and durability.

DIAGRAM FOR DETECTION PANEL INSIDE

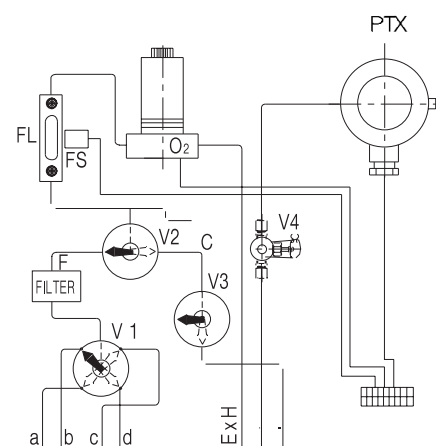

- FL : Flow indicator
- F : Filter
- O2 : Oxygen sensor
- PTX : Pressure transmitter for vapour
- V1 : Oxygen sampling line(selecting valve)
- V2 : Mode selection
- V3 : Cleaning air stop valve
- V4 : Test valve for press. transmitter
- a : Port(F)
- b : Port(A)
- FS : Flow alarm sensor
- C : Calibration gas connector
- c : ST' BD(F)
- d : ST,BD(A)

TECHNICAL SPECIFICATION

SYSTEM

- Main power supply : AC 110/220V, 50-60Hz
- System power : DC 24V
- Air supply : 4-7bar
- Function : - Inert gas pressure display(0-200mbar)
 - Inert gas high pressure alarm(120mbar)
 - Inert gas low pressure alarm(10mbar)
- Oxygen content display(0-25% V% O2)
 - Oxygen content high alarm(8 V% O2)
- Flow failure alarm(If the flow is stopped)
- External alarm(option)
- Enclosure : EEx ia II C T4

PRESSURE TRANSMITTER

- Range : 0-200mbar
- Output : 4.....20mA
- Accuracy : $\pm 0.2\%$ of F.S
- Power supply : 17-28vdc
- Safety : EEx ia II C T4

DIGITAL INDICATOR

- Size : 48H x 96W x 112D
- Output contact : H and L alarm
- Input : 4.....20mA

OXYGEN SENSOR

- Range : 0-25% O2
- Output : 4.....20mA
- Accuracy : $\pm 2\%$ of F.S
- Power supply : DC 24V
- Safety : EEx ia II C T4

ALARM ANNUNCIATOR

- 10 channel type
- Function : Accept horn, Accept flash, Test function
- Power supply : DC 24V

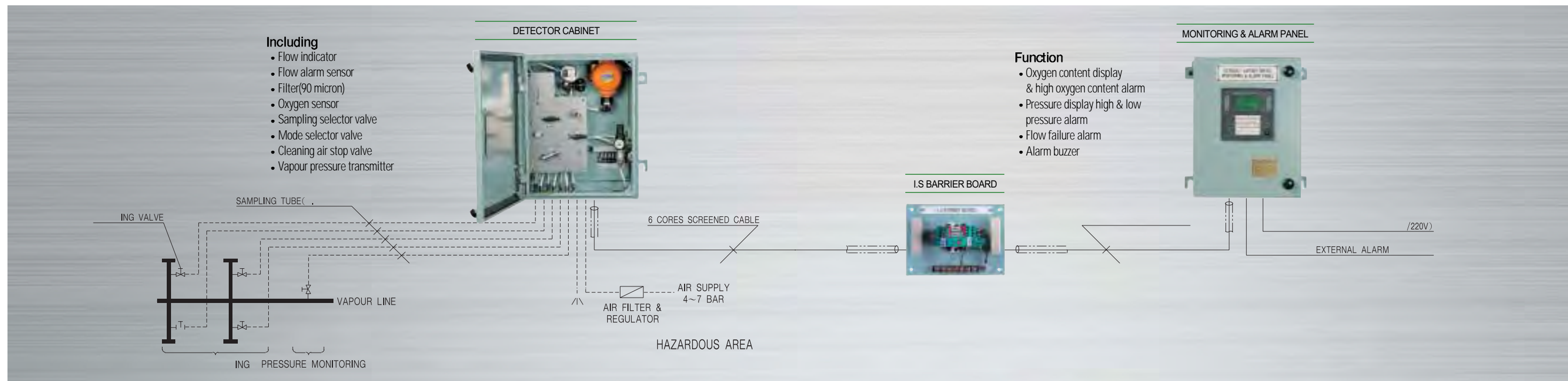

Cargo Tank Measuring System

PURPOSE

The Fixed gas sampling system is dedicated to the Gas Control in all Tanks, Void Spaces, Pump room or Houses adjacent to Cargo Storage Tanks and Handling Systems. In order to detect any Gas Concentration level over programmable limits and to monitor visible and audible alarms consequently, these areas are controlled by the suction process sampling on one or more common sensor(s) as well as by individual local sensors.
This system complies with ISGOTT regulation chap. 7.8 and 8.2.

SYSTEM DESCRIPTION

The Fixed gas sampling System is composed of :

ANALYSING UNIT

A cabinet named Analyzing Unit includes suction process sampling gas sensor(s) and pneumatic components for up to 48 channels (pumps, solenoid valves, water trap filter, pressure sensor, ...).
A modular arrangement of solenoid valves allows easy sizing of channels number, easy extension as well as easy maintenance.

An electronic module manages above parts, monitors up to 7 gas sensors dispatched either in suction process or as local sensor, performs all gas measurements from above sensors, and monitors the alarms on dry contact outputs. It comprises 4 digital RS485 communication ports Unit(s) as described hereunder, and/or an external Monitoring System using MODBUS RTU protocol. The Unit is powered equally by 220 or 110 VAC.

CONTROL UNIT

One or more panel(s) named Control Unit include an electronic module managing a LCD screen for measurement and alarms display, status lamps, buzzer/dry contact output for alarms monitoring and keyboard for System operation and configuration.
The large LCD screen increases the data availability and the man-machine interface is simplified for easy access to functions and configuration using spread menus.

One Control Unit can be incorporated in the Analyzing Unit or located in a remote box, another one can be located in another place. The Control Unit is powered by 24VDC from the Analyzing Unit, and communicates with it by RS485 link.

ANALYZING UNIT WITH CONTROL UNIT



SUCTION SAMPLING ACCESSORIES

A set of suction sampling accessories is composed of safety chamber, non-return valves, flame-arrestors, shut-off valves. On each channel, a flow regulating valve allows to get an identical flow whatever is the length of the line, for best efficiency of the system.

LOCAL GAS SENSORS

When required, a set of local gas sensors of infra-red, catalytic, electro-chemical or any other type, 4-20mA output, can be connected to the Analyzing Unit.

SAFETY CHAMBER



Local gas sensors

- Conn. Size : 5K 25A FF
- Material : SUS316
- Signal line : PT 3/8 "
- Protection device is used for avoiding water suction.

NON-RETURN CHECK VALVE



Local gas sensors

- Conn. Size : O.D 8mm
- Material : SUS316

SPECIFICATIONS

- Suction channels number : up to 48, connections for O.D. 8 mm copper pipes
- Suction capacity : up to 500 meters w/ O.D. 8 mm pipes
- Sampling exhaust output : connection for O.D. 8 mm copper pipe to safe area
- circulation exhaust output : connection for O.D. 8 mm copper pipe to safe area
- Drain water trap output : connection for O.D. 8 mm copper pipe to safe area
- Calibration gas input : connection for O.D. 8 mm plastic pipe
- 4-20mA Analog calibrated inputs for sampling or local sensors : up to 7
- Gas concentration alarm levels : 2 adjustable, Pre-Alarm and Main alarm
- Alarm form Analyzing Unit, dry contact outputs : 1 for Gas alarm
1 for System alarm
1 for remote Horn / Rotating Lamp
1 for Power Supply failure
- Alarm from Control Unit : 1 internal buzzer + 1 dry contact output
- Communication ports : 4 RS485, 1 RS232 (Analyzing Unit)
1 RS232 or RS485 (Control Unit)
- Output power supply for sensors : 24 VDC
- Instrument air supply for purge : 7 / 10 bars, connection for O.D. 8 mm copper pipe
- Sensors : miscellaneous type according to gas type Safety class according to their location
- Operating temperature for Analyzing and Control Units : 0 °C to + 70 °C
- Location for Analyzing and Control Units : Safe area in enclosed space (Control Room, accommodation, bridge, ...)
- Power Supply : 110/220 VAC and Other voltages on request

GENERAL DIAGRAM FOR FIXED GAS SAMPLING SYSTEM

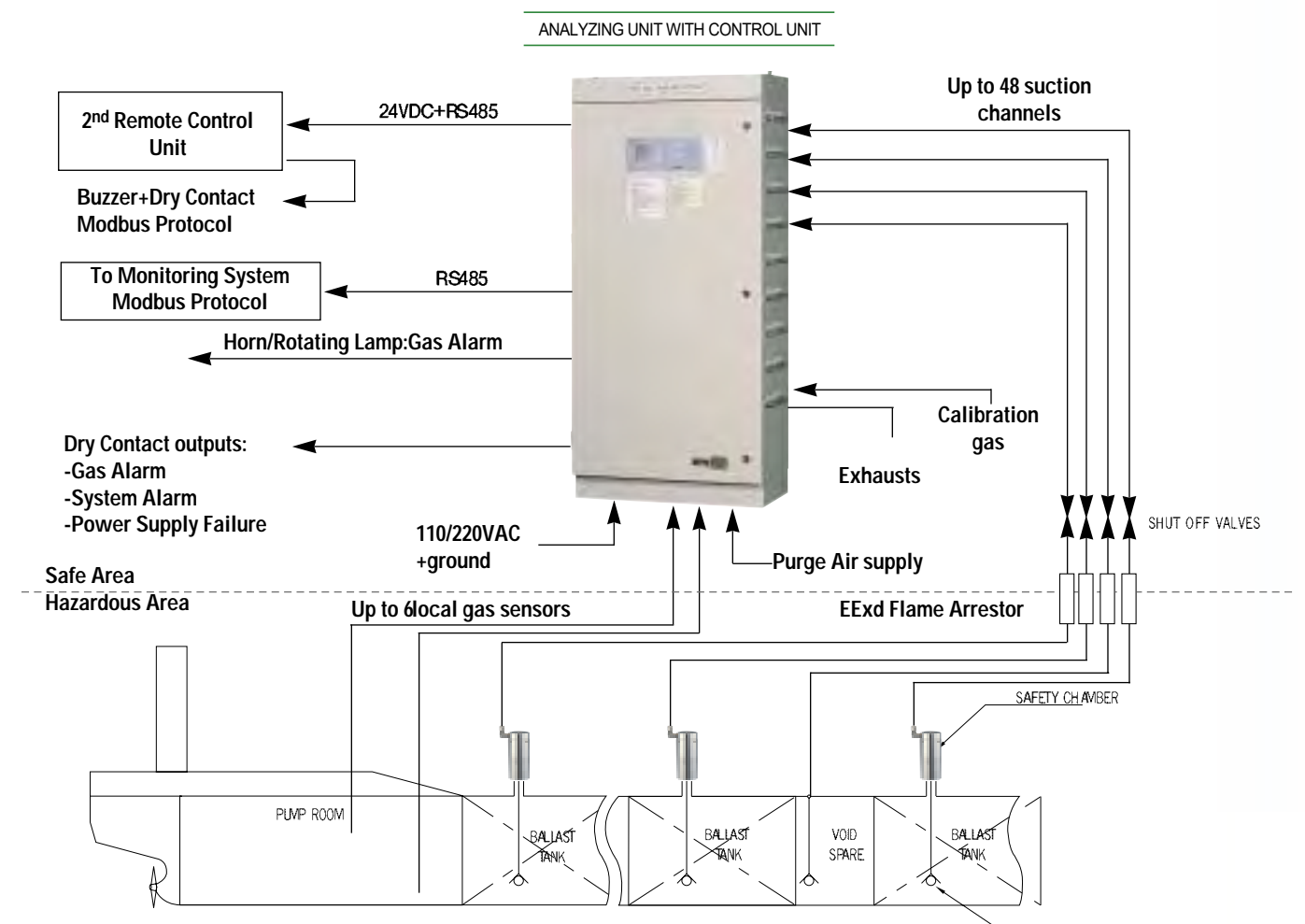

PUMP AND MANIFOLD PRESSURE MONITORING SYSTEM

Cargo Tank Measuring System

PRESSURE SENSOR FOR SUBMERSIBLE TYPE



PRESSURE SENSOR FOR DECK MOUNTING TYPE



GENERAL

1)Vapour pressure monitoring

The Cargo tank ullage space pressure monitoring with high & low pressure is required by SOLAS 74, Chapt. II-2 Req. 59. This monitoring system is required to preventing serious deformation of the tank structure such over and under pressurization when the tank venting system is in failure.

2)Manifold pressure and Pump Suction and discharge pressure monitoring

The Manifold pressure and pump suction & discharge pressure shall be indicated from CCR. Pressure transmitter will be installed on the dry space and in ballast tank.

3)Vapour return pressure monitoring

This transmitter is required for remote monitoring and high/low alarm from CCR The pressure transmitter will be installed near in cargo manifold.

FEATURES

- Intrinsically safe detecting is applicable to all of inflammable fluids
- Individual pressure displays
- Anti-corrosion material of pressure sensing part
- High accurate reading vacuum pressure
- Easy calibration and maintenance
- Very strong flash mounting diaphragm
- Zero and span internal adjustable
- All stainless steel material
- Intrinsically safe EEx ia II C T5
- Self-diagnostic function

PRINCIPLE OF OPERATION

The Intrinsically Safe Type Vapour Pressure Monitoring System is intended for Cargo tank pressure monitoring. This system consists of pressure transmitter which has a high quality, accuracy, durable construction suited for excessive pressure and I.S barrier. The output signal which arise by pressure transmitter is transmitted to indicator panel or alarm monitoring system through I.S

barrier located in safety area. The high and low pressure alarm can be classified into two types which are on-deck mounting type and submersible mounting type in accordance with detection position of pressure.

APPLICATIN

- Cargo pump pressure
- Cargo manifold pressure
- Vapour return line pressure
- Tank cleaning pump pressure
- Fire main line pressure
- Ballast pump pressure

TECHNICAL SPECIFICATION

PRESSURE SENSOR

- Accuracy : $\pm 0.2\%$ F.S. at 20 °C
- Environmental protection : .Transducer : IP68, 10Bar~40Bar
- Indoor amplifier box : IP66
- Outdoor amplifier box : IP67
- Operating temperature : .P.E. cable : -40~ +80 °C
- FEP cable : -40~ +120 °C
- Diaphragm material : Caramic Al2O3
- Material : .Sensor body : SUS316L
- Indoor amplifier box : SCS13
- Outdoor amplifier box : SCS14

DEMENSIONS/INSTALLATION

ON-DECK MOUNTING TYPE

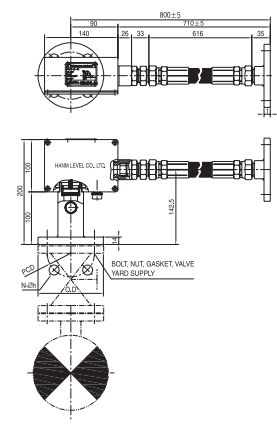

SUBMERSIBLE TYPE

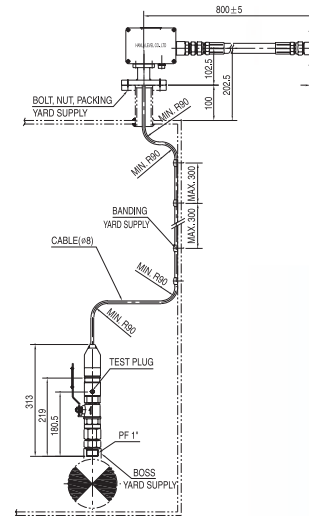

TECHNICAL SPECIFICATION



ONE LINE BLOCK DIAGRAM

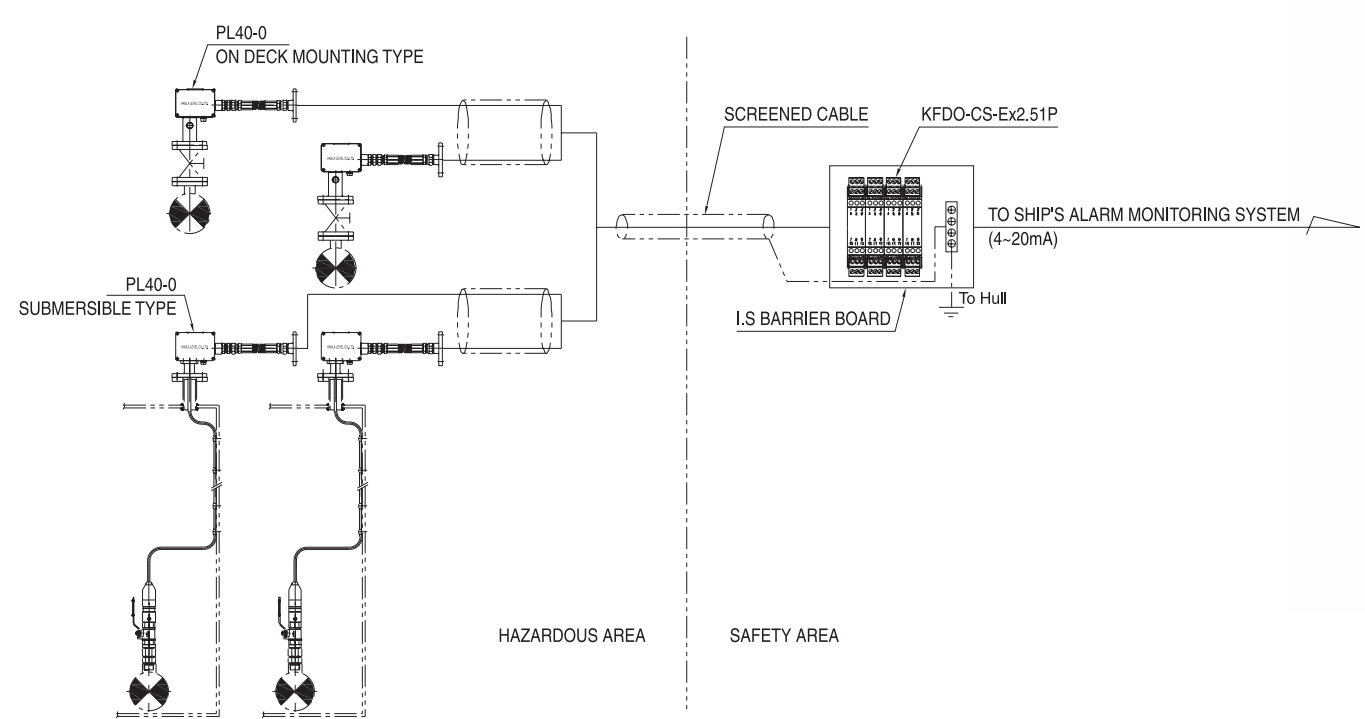

TANK LEVEL MONITORING SYSTEM

Tank Remote Sounding System

* AIR PURGE TYPE REMOTE LEVEL GAUGING SYSTEM(PURE PNEUMATIC TYPE)

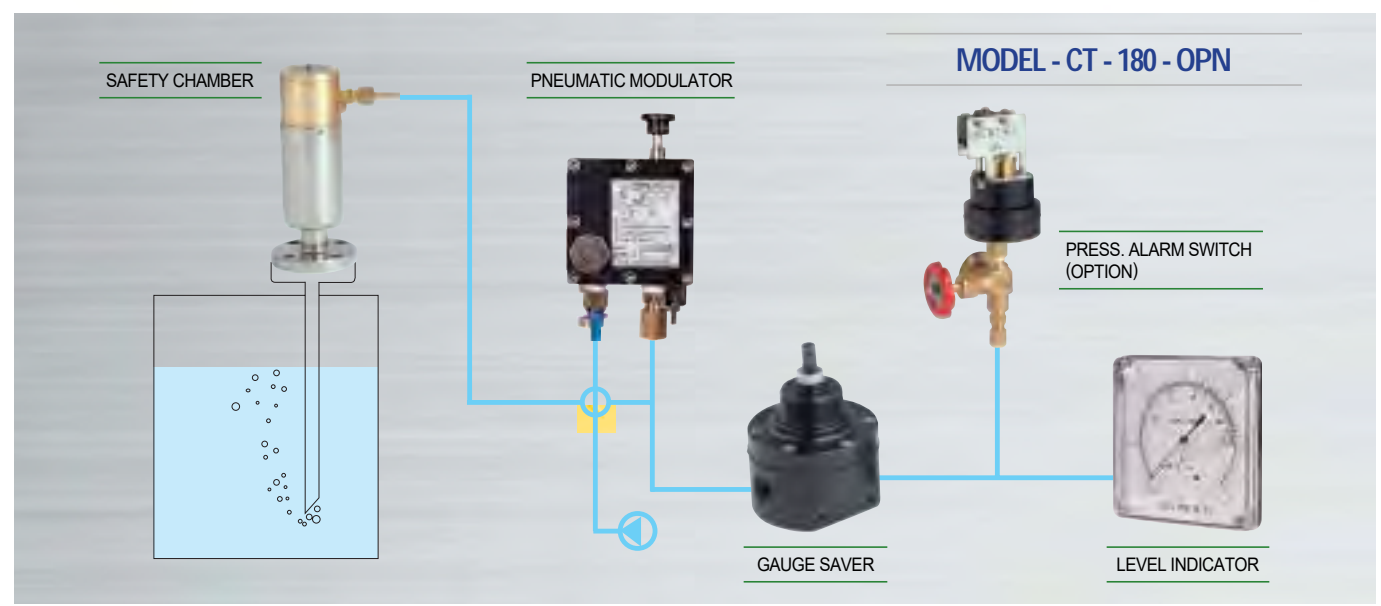

OPERATING PRINCIPLE

- The operating principle is based upon the measurement of the hydrostatic pressure by providing a constant low flow of air or neutral gas into a probe which opens at the tank bottom.
- The flow regulator ensuring a constant pre-set flow at the end of the sounding pipe in the tank irrespective of the supply pressure.
- Gauge saver is used for protecting the level indicator against over pressure.
- The blowing valve is used for sending the full air pressure through the signal line for cleaning purposes.
- The air supply valve is used for isolation from other channel without any influence.
- Principle Diagram

FEATURES

- Liquid level or measuring depth pressure is indicated for direct reading, and then the high precision is achieved.
- The construction is simple and the handling and maintenance is easy.
- Since no electricity is used, the explosion-proof measure is not necessary.
- With use of the pressure type high sensitive level switch, the signal and alarm of the preset liquid level can be transmitted.

APPLICATIONS

- 《CT-180-OPN》
- OPEN TANK-Ballast tank remote reading
 - Draft remote reading
 - Heeling and trim remote reading
 - Fuel oil tank remote reading

STANDARD SPECIFICATION

- System type : One line type air purge system
- Flow rating : 10-80NI/hour
- Working temp. : -30°C~70°C
- Supply air setting pressure : 4.5 kg/cm²
- 400m Max. distance of signal line and indicator
- Signal line size : OD8 or OD10
- Range : 1 to 40 meter
- Accuracy : ±0.5% os F.R(optional)
±1.0% os F.R

PRINCIPLE DIAGRAM

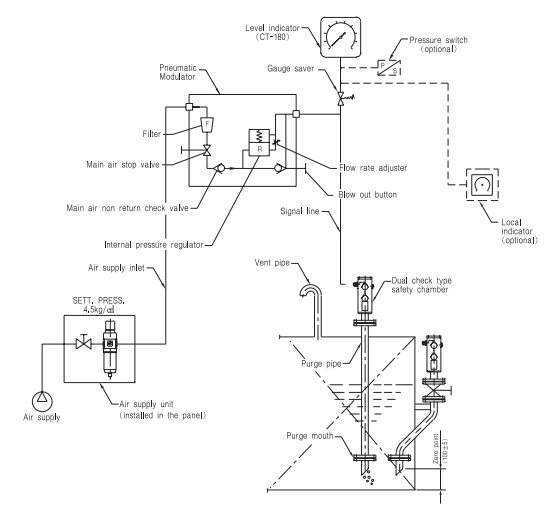

- The output pressure of this modulator(Corresponding to the hydrostatic pressure at the bottom of the sounding pipe)is connected to the level indicator.
- The indicator and modulator are built in interconnecting assembly ready for panel mounting.

COMPONENTS OF SYSTEM

DUAL CHECK TYPE SAFETY CHAMBER(AIR PURGE HEAD)

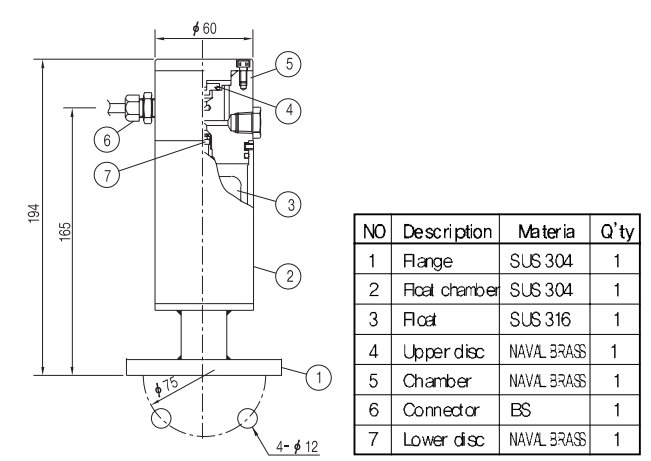

- Avoids entry of liquid inside the device in case of air supply failure.
- Connection size : JIS 5K 25A, or 5K 20A.
- Working pressure : Max. 10 kg/cm²
- Connection size of local test device : PT 1/4"
- Material : Naval brass.
- Including local test device for check of actual level.

LEVEL INDICATOR WITH GAUGE SAVER

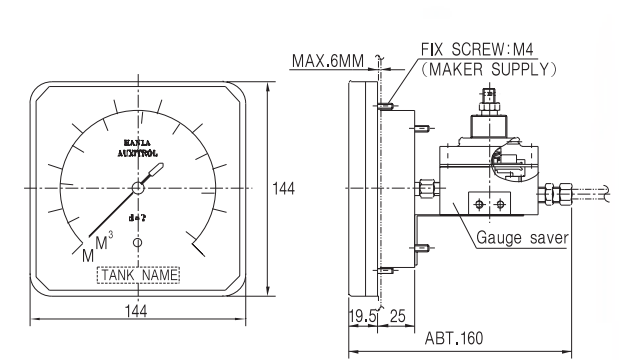

LEVEL INDICATOR

- Size:144 ×144
- Class 1.5 standard
- Class 1.0 option
- Class 0.5 option
- Graduation : Height or volume
- Including the zero adjuster

GAUGE SAVER

- Body material : AL6061
- Differential : Below 0.01 kg/cm²
- Including the range adjuster

PNEUMATIC MODULATOR

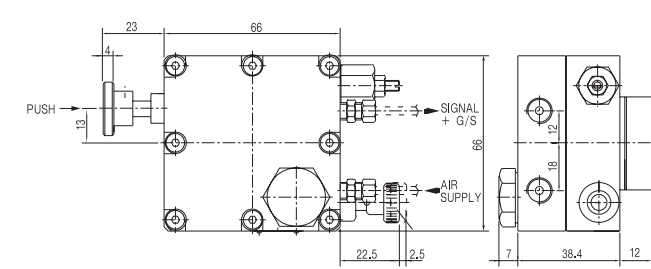

- Air pressure : 4.5 kg/cm²
- Flow rating : 10-80NI/h
- Blowing pressure : 4.5 kg/cm²
- Connection : Air supply-PT1/8" Signal line-PT1/8"
- Including the Flow rate adjuster and main air non-return check valve

SPECIAL PURGE UNIT

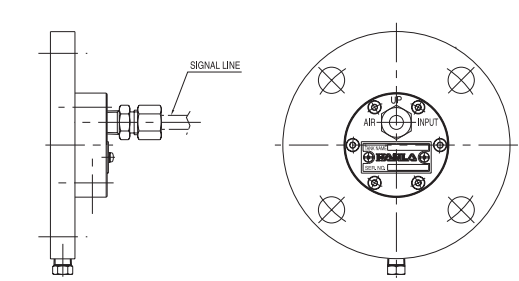

SYSTEM EXAMPLE

CT-180-OPN

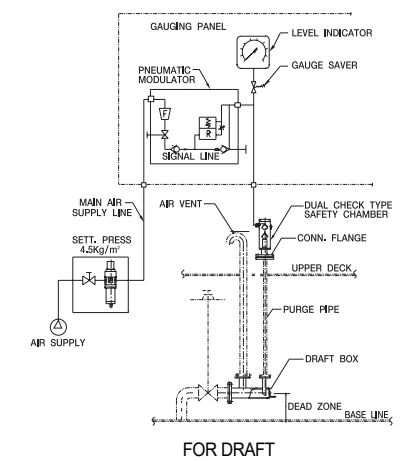
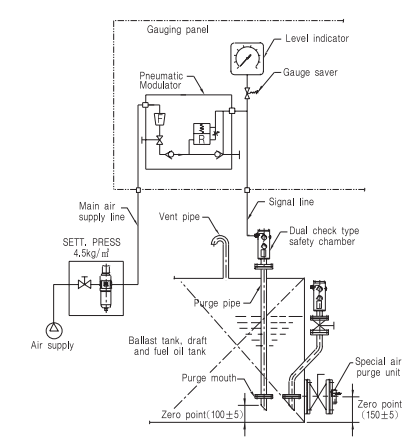

TANK LEVEL MONITORING SYSTEM

Tank Remote Sounding System

* AIR PURGE TYPE REMOTE LEVEL GAUGING SYSTEM(ELECTRO PNEUMATIC TYPE)

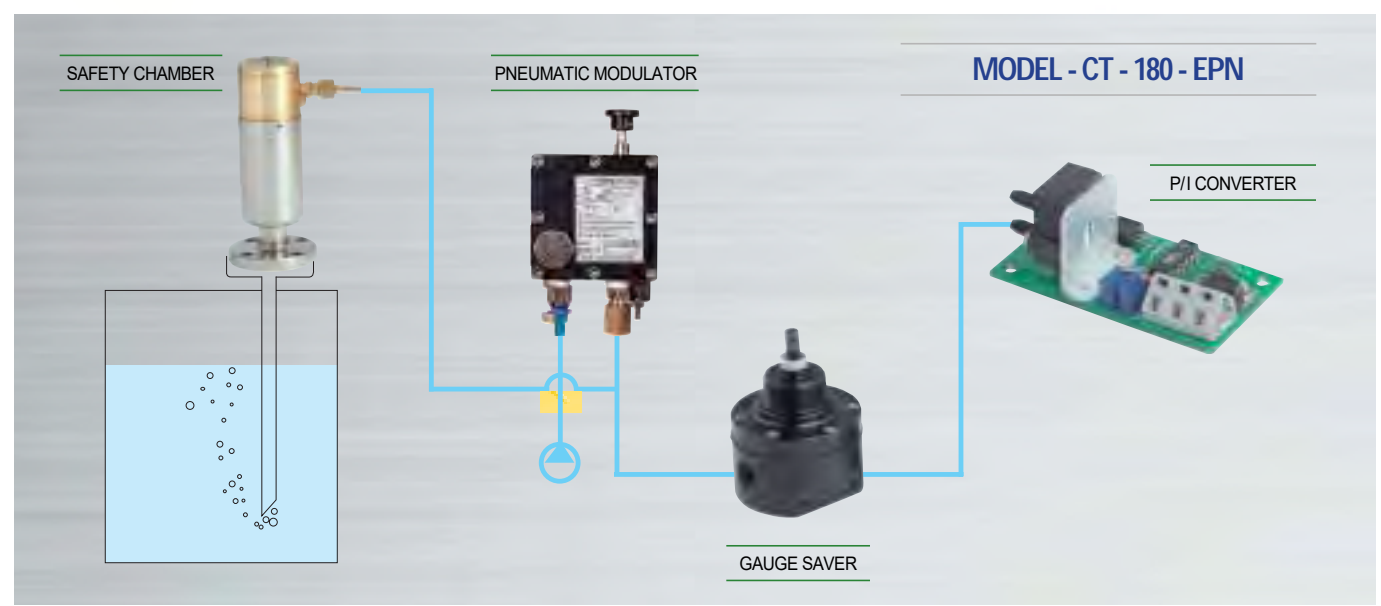

PRINCIPLE DIAGRAM

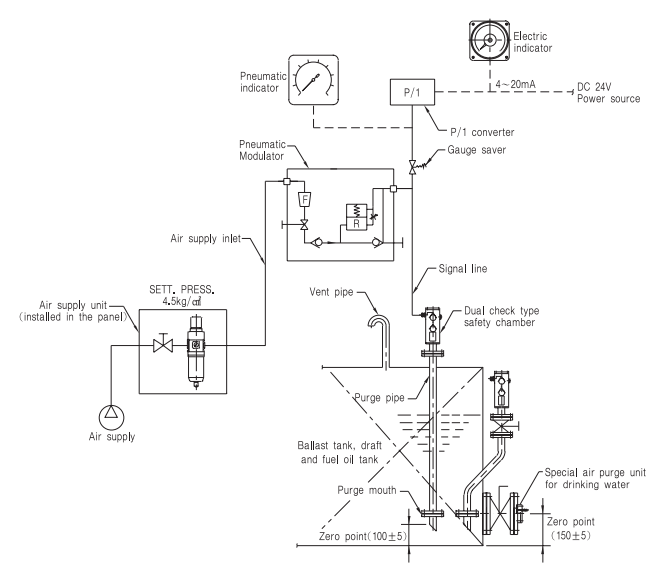

- The flow is produced by means of an automatic air flow modulator, type which includes:
- An air supply filter
 - An air flow regulator ensuring a constant pre-set flow at the end of the bubble pipe in the tank irrespective of the supply pressure.
 - A safety valve protecting the indicator and pressure transmitter against over pressure.
 - The air supply valve is used for isolation from other channel without any influence.
 - The blowing valve is used for sending the full air pressure through the signal line for cleaning purposes.

OPERATING PRINCIPLE

The operating principle is based upon the measurement of the hydrostatic pressure by providing a constant low flow of air or neutral gas into a probe which opens at the tank bottom. The output pneumatic signal of the modulator is fed into P/I converter and is changed to electric signal(4~20mA) in 2 wire by P/I converter. The electric output signal(4~20mA) can be connected to C.R.T display cargo system, Digital indicator, analogue type indicators, etc. or a combination of these systems.

FEATURES

- Liquid level of measuring depth pressure is indicated for direct reading, and then the high precision is achieved.
- The construction is simple and the handling, and maintenance is easy.
- 4~20mA output signal/Two wires.

APPLICATIONS

- Ballast tank remote reading
- Draft remote reading
- Fuel oil tank remote reading
- All liquids even viscous ones (molasses, bitumen etc..)

STANDARD SPECIFICATIONS

- System type : One line type air purge system
- Flow rating : 10~80NI/h
- Working Temp. : -30°C~70°C
- Supply air setting pressure : 4.5kg/cm²
- 400m Max. distance of signal line and indicator
- Signal line size : OD 8 or OD 10
- Range : 1 to 40 meter
- Output : 4~20mA 2wire system
- Power supply : 16 to 32V DC
- Accuracy : ±0.5% of F.R
±0.2% of F.R(optional)

COMPONENTS OF SYSTEM

DUAL CHECK TYPE SAFETY CHAMBER(AIR PURGE HEAD)

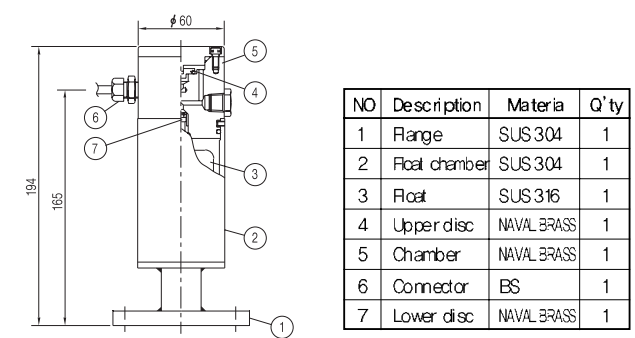

- Avoids entry of liquid inside the device in case of air supply failure.
- Connection size : JIS 5K 25A, or 5K 20A.
- Working pressure : Max. 10kg/cm²
- Connection size of local test device : PT 1/4"
- Material : Naval brass.
- Including local test device for check of actual level.

TRANSMITTER PANEL

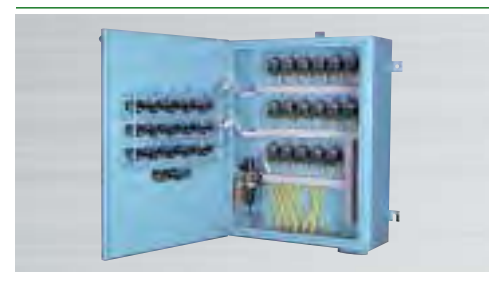

P/I CONVERTER

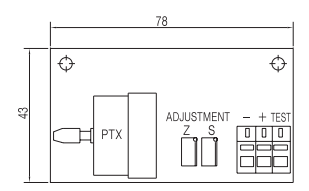

- The transmitter is linked to an integral air regulator and consists of :
- a sensyn piezoresistand type sensor
- an electronic unit which converts the signal from the sensor into a standard 2 wire, 4-20mA signal
- Power supply From 18 to 36VDC
- Output signal : standard 4-20mA(2 wires)
- Accuracy : ±0.2%, OF F.S
- Enclosure : EEx ia IIc T6

GAUGE SAVER

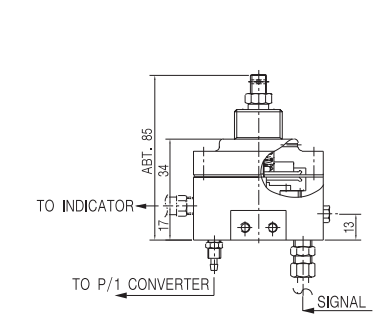

- Body material : AL6061
- Differential : Below 0.01 kg/cm²
- Including the range adjuster

SPECIAL PURGE UNIT

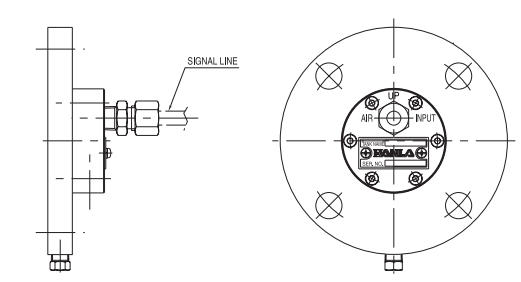

PNEUMATIC MODULATOR

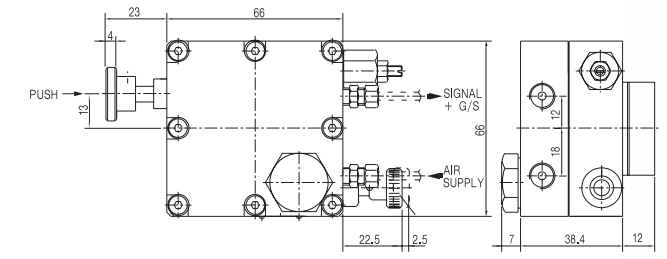

- Air pressure : 4.5kg/cm²
- Flow rating : 10~80NI/h
- Blowing pressure : 4.5 kg/cm²
- Connexion : Air supply-PT 1/8"
- Signal line-PT 1/8"
- Including the flow rate adjuster and main air non-return check valve

SYSTEM EXAMPLE

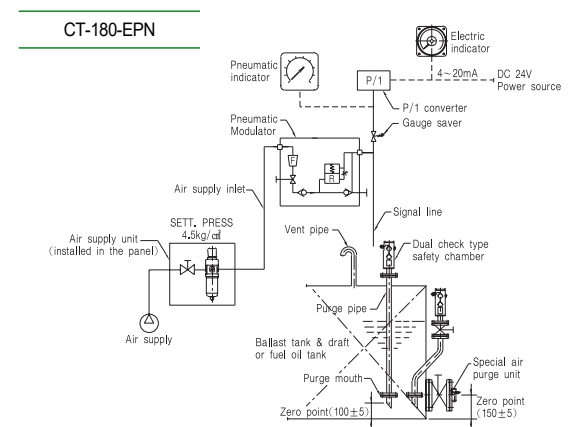

GENERAL WIRING DIAGRAM

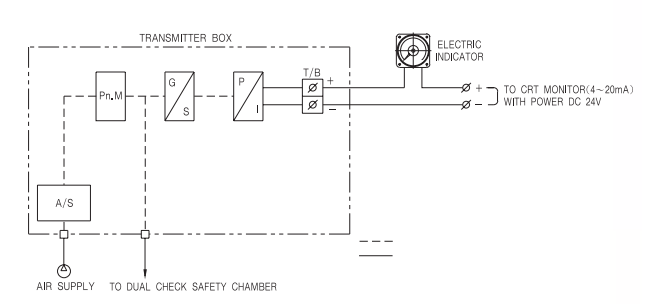

Tank Remote Sounding System

PURPOSE

The Microprocessor Controlled Electro-Pneumatic Level Monitoring System is dedicated to the Level Monitoring in all kinds of Tanks, such as Ballast tanks and Oil Tanks.

It is possible to display individual tank name, corrected level and corrected volume on Display Unit.

CT-180-MPN is consist of Measurement Unit and Display Unit.

The operating principle is based on the measuring the hydrostatic head of the liquid by providing constant low flow of air into probe(called as sounding pipe) which mount at the tank bottom. When the air(supplied from modulator) is discharged through the purge mouth at the tank bottom, an air pressure corresponding to the liquid level considering the viscosity will be built up in the sounding pipe. If the specific gravity of the liquid is known and a pressure in the sounding pipe is measured, it is possible to calculate the distance from the pipe opening to the surface.

SYSTEM DESCRIPTION

The Electro-Pneumatic Level Monitoring System is composed of :

Measurement Unit : HPI-100

A cabinet named Measurement Unit includes 8 Pressure Sensors, 3 Relay control for solenoid valve and Display LCD. It is possible to measure the Level up to 24 Tanks per 1 unit.

A modular arrangement of solenoid valves controlled by Relay allows easily changing the measuring channel.

An electronic module manages above parts, measures up to 24 Tanks. It comprises 1 digital RS485 communication port as described hereunder, and/or an Display LCD, using MODBUS RTU protocol. The Unit is powered by 24V DC.

Display Unit : HDU-100

Display Unit includes an electronic module managing a LCD screen for measurement and alarms display, status lamps, buzzer/dry contact output for alarms monitoring and keyboard for system operation and configuration.

The large LCD screen increases the data availability and the man-machine interface is simplified for easy access to functions and configuration using spread menus.

Display Unit can be incorporated in the Measurement Unit and Analog Input Unit in another panel. The Display Unit is powered by 24 V DC, and communicates with it by RS485 link.

ELECTRO-PNEUMATIC LEVEL MONITORING SYSTEM (CT-180-MPN)



NON-RETURN CHECK VALVE



For Sounding Pipe

- Conn. Size : 5K 25A FF
- Material : SUS304/
NAVAL BRASS
- Signal line : PT 1/4"
- Protection device is used for avoiding water suction.

SPECIFICATIONS

- Measurement Channel Number per 1 Module : up to 24(Std.) and other points on request
- Measurement Height : 40mH2O
- Air Consumption : 5-30N ℓ/hour
- Air Supply Pressure : 6-10 kgf/cm2
- Measurement accuracy : +/- 20mm
- Signal pipe : connection for O.D. 8mm pipe
- Alarm Display Unit : 1 internal buzzer + 1 dry contact output
- Communication ports : 2 RS485, 1 RS232 (Display Unit)
1 RS485 (Measurement Unit)
- Internal power supply : 24 V DC
- Operating temperature for :
 - Level monitoring pane : 0 °C to ++ 70 °C
 - Tank side : -20 °C to + 70 °C (Std.)
-35 °C to + 70 °C (With membrane dryer)
- Location for Measurement and Display Units : Safe area in enclosed space (Control Room, accommodation, bridge, ...)
- Power Supply : 110/220 V AC and Other voltages on request

GENERAL DIAGRAM FOR ELECTRO-PNEUMATIC LEVEL MONITORING SYSTEM CT-180-MPN

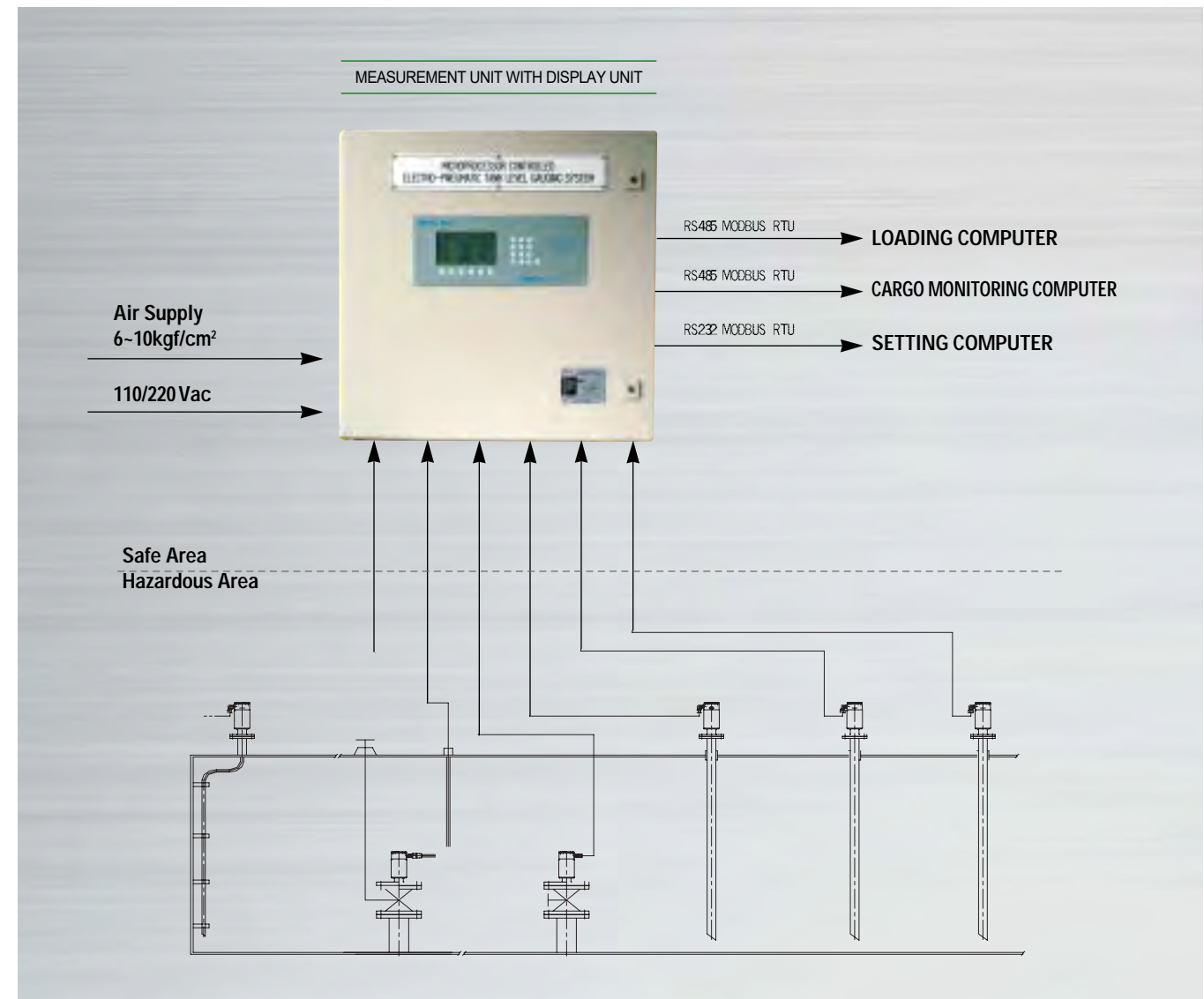

TANK LEVEL MONITORING SYSTEM

Tank Remote Sounding System

* ELECTRO-PNEUMATIC TYPE REMOTE LEVEL GAUGING SYSTEM

MODEL : PL-40P



The PL-40P transmitter is designed to be mounted on the top of the tanks.
The PL-40P transmitter allows a remote level measurement using a 4-20mA analog output, while keeping the principle of bubbling.

TECHNICAL FEATURES

- Transmitter : 2 wire 4-20mA
- Pressure scale : from 40 up to 4000 mbar.
- Pressure of supply : 4 to 10 bar.
- Accuracy : 0.2% of the measured scale.
- Power supply : 18 to 36VDC.
- Operating temperature : -20°C~70°C
- Automatic bubbling line clearing.
- Protection category.
- EEx ia IIC T5

Data acquisition and display from analog signal(4-20mADC) with completely compatible PC(color screen)



- Analog(bargraph) and numeric level display.
- Volume(tank table) display.
- Temperature display.
- Alarm status and warning signal.
- Analog or RS 485 transmission.
- 16 to 48 channels.
- User friendly.(Ask for our documentation MIC/90E)

PRINCIPAL PIPING DIAGRAM & INSTALLATION MOUNTING

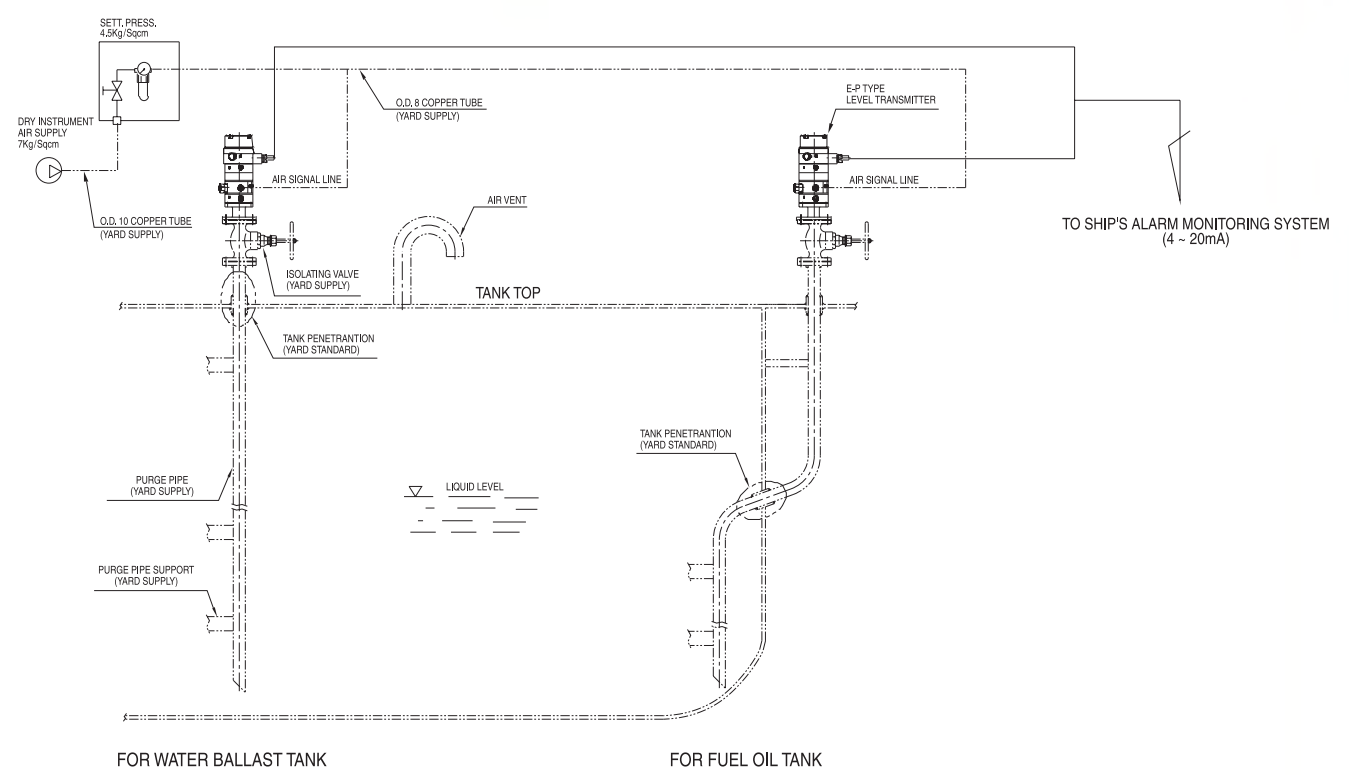

GENERAL WIRING DIAGRAM

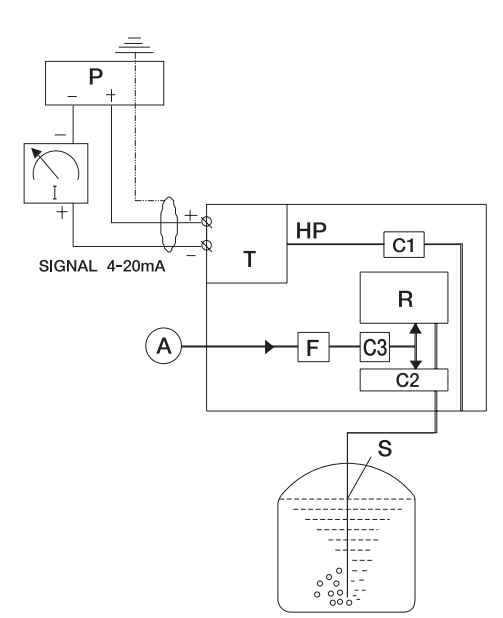

- A : Air pressure
- C1 : Over pressure safety valve
- C2 : Safety valve through air supply pressure
- C3 : Non return shut-off valve
- F : Filter
- T : Transmitter(4-20mA)
- R : Automatic flow regulator
- S : Probe
- P : Power supply (18-36V DC)
- I : Indicator

DIMENSION

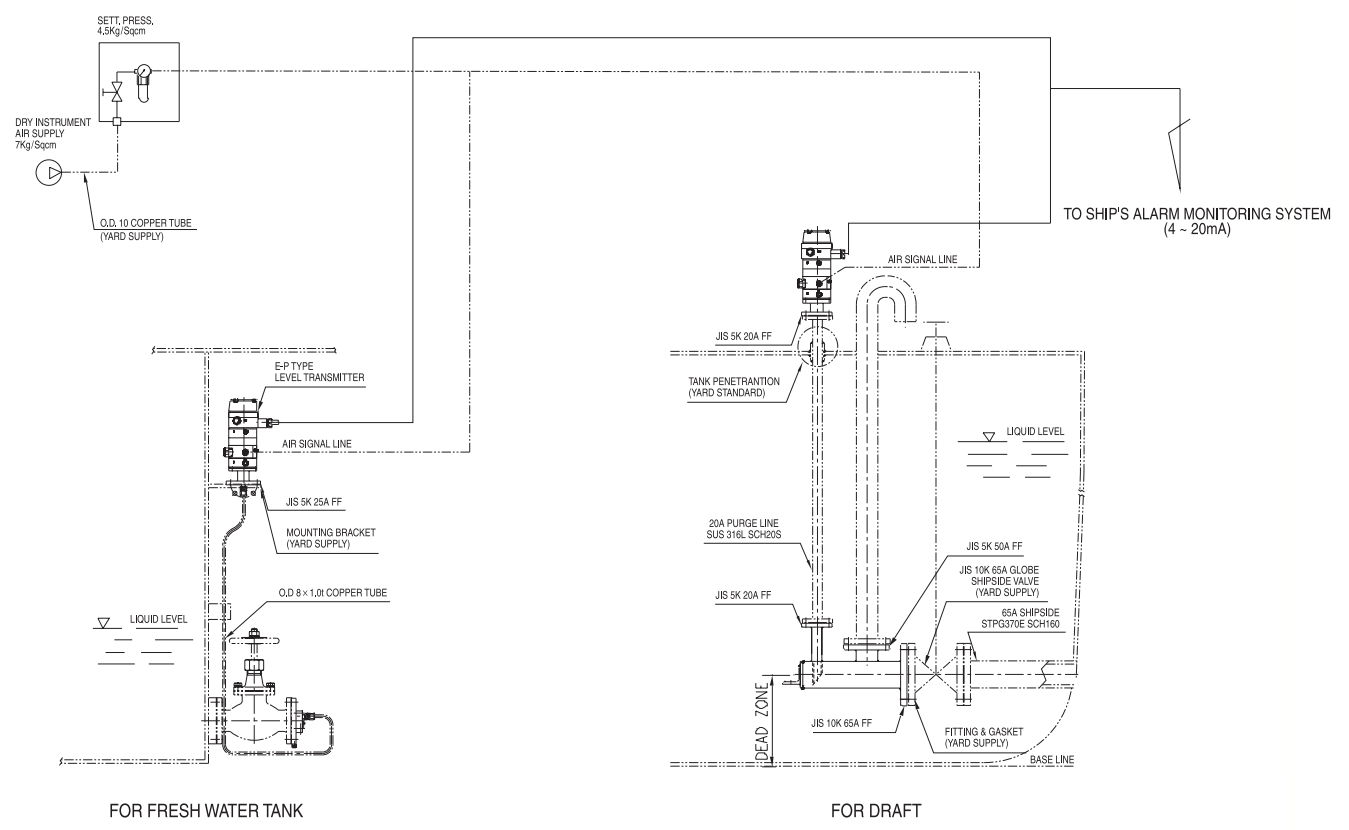
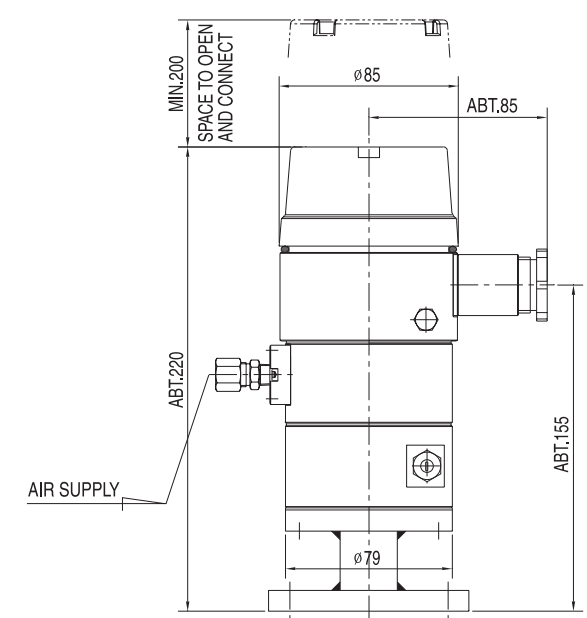

Tank Remote Sounding System

MODEL : PL-40

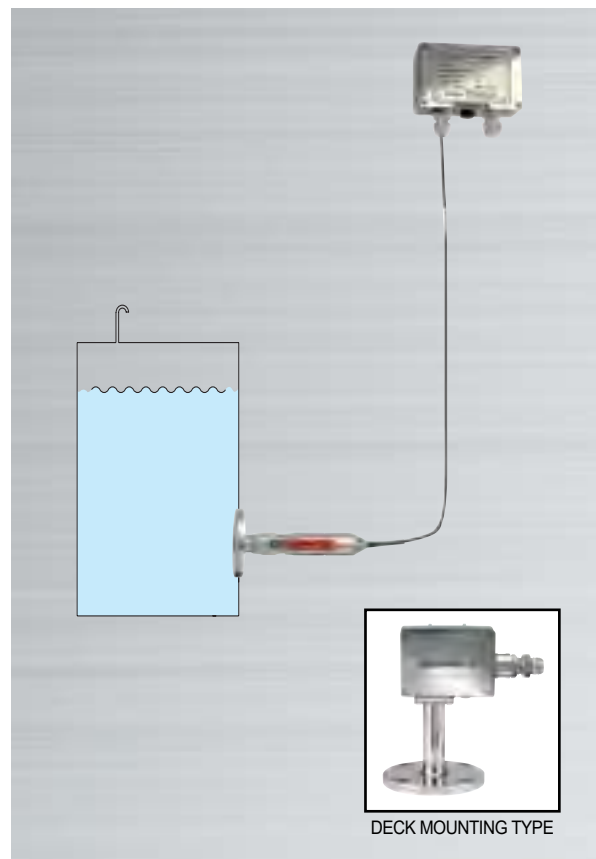

OPERATING PRINCIPLE

The Hanla Level Transmitter is for continuously measuring the liquid level of ballast tank, draft and fuel oil tank in the marine ships as well as tanks containing media.

The PL-40 is a 2-wire, 4~20mA level transmitter consisting of a transducer and an amplifier connected via a submersible vented cable.

Pressure change in the front of the diaphragm will bring about a capacitance change in the cell of the transducer.

This change will be transmitted to amplifier as a change in the electrical signal.

The PL-40 is manufactured in several ranges, and available. Especially the electro pressure type level transmitter can be connected to C.R.T. display cargo system, loading computer, indicator, and analogue type indicator to measure the actual level.

TECHNICAL SPECIFICATION

- Output : 4 ... 20mA adjustable
- Accuracy : ±0.2% F.S at 20°C
- Supply voltage : 12 ... 28VDC
- Range : Gauge 175mbar to 4bar
Absolute 1400mbar to 4bar
- Overpressure : Gauge 6bar to 25bar
Absolute 10bar to 25bar
- Diaphragm cell : Capacitive transmitter with ceramic diaphragm
- Materials
 - _ Diaphragm : Ceramic
 - _ Sensor Body : Stainless steel 316L
 - Amplifier box : SCS 13(Indoor) / SCS 14(Outdoor)
 - _ Special cable : Sheathed polyethylene cable
- Operating temperature range
 - _ Transducer : -40~125 °C
 - _ Amplifier : -25~85 °C
- Protection class
 - _ Transducer : IP68/submersible
 - Amplifier : IP66(Indoor) / IP67(Outdoor)
- Intrinsic safety : EEx ia IIc T6 (Max. 50m cable between transducer and amplifier box)
- Cable length : 3m in standard(option : up to 50m)

FEATURES

- High measuring accuracy
- Excellent stability
- Capacitive transmitter with Ceramic diaphragm
- High overload limit
- High temperature stability
- Corrosion resistance
- No hysteresis
- Marine class approval

APPLICATIONS

- Ballast tank remote reading
- Draft remote reading
- Heeling and trim remote reading
- Fuel oil tank remote reading
- Waste waters, wells, locks, rivers etc.

MODEL NUMBER CODE SYSTEM

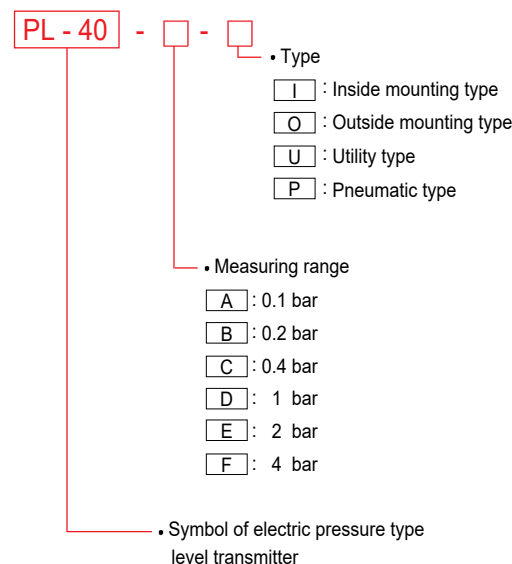

INSTALLATION METHOD

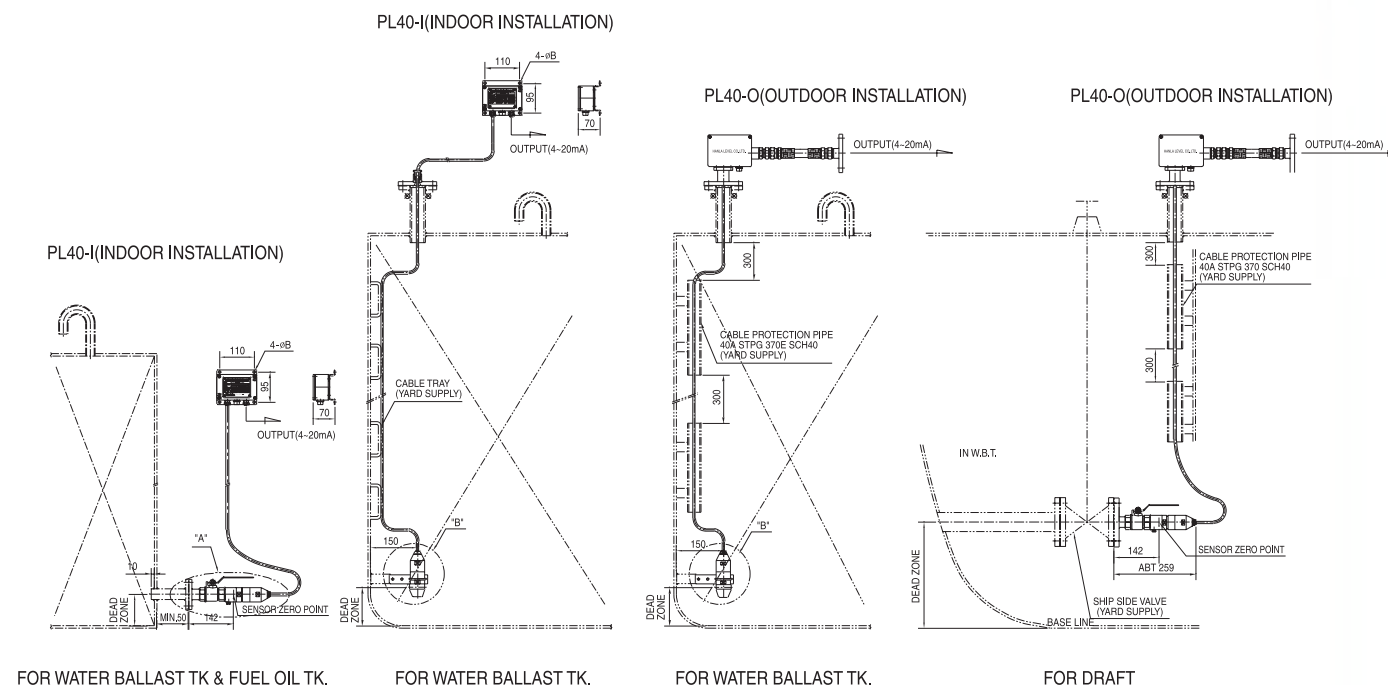

GENERAL WIRING DIAGRAM

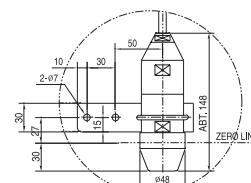
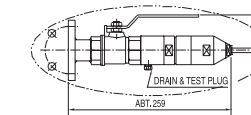
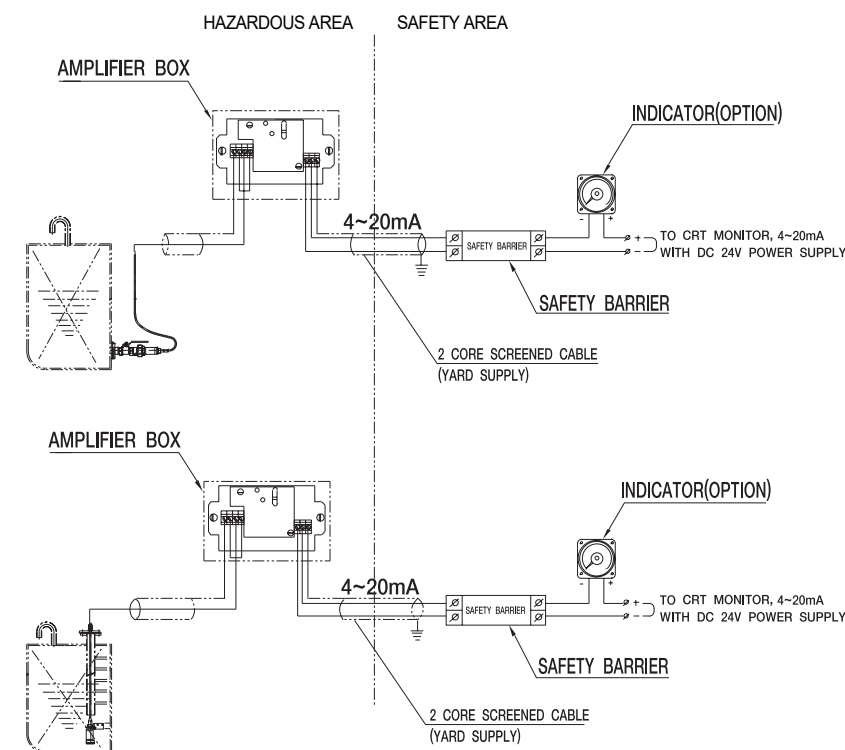

Water Ingress Detection System

GENERAL & APPLICATION

This system has been specially designed, manufactured for detecting the presence of water in the **cargo holds** and **closed dry or void space** where the volume exceeds 0.1% of the ship's displacement volume on summer load water line, located partially or totally forward of the foremost card hold, and **ballast tanks** located forward of the foremost cargo hold, collision bulkhead of Bulk carrier in conformity with SOLAS regulation XII/ 12 rule requirements.

THE POSITION OF DETECTION

- A reliable indication of water reaching a present level will be supplied on our water ingress detection system according to following installation position required by SOLAS regulation XII/ 12.
- These level switches should be installed either in the aft part of each cargo hold or in the lowest part of the spaces other than cargo holds to which these requirements apply.

● For Cargo Hold :

- 1) An alarm, both visual and audible for which the space is identified on the main alarm panel will be activated when the depth of water at the level sensor reaches the pre-alarm in the space being monitored.
- 2) An alarm, both visual and audible on the main alarm panel will be activated when the level of water at the sensor reaches the main alarm level, indicating increasing water level in a cargo hold. In addition, the both alarms will identify the space and the audible alarm should not be the same as that for the pre-alarm level.

● For compartments other than cargo holds:

- 1) An alarm, both visual and audible, indicating the presence of water in a compartment other than a cargo hold on the main alarm panel will be activated when the level of water in the space being monitored reaches the sensor. The visual and audible characteristics of the alarm indication will be the same as those for the main alarm level in a hold space.

FEATURES

- Intrinsically safe detection can be applicable to all of inflammable area, if required.
- Available for any number of detecting points
- Available for applying various type level switch according to configuration of the tank
- Available for the overriding device for which the alarm can be deactivated or reactivated

SYSTEM SELECTION FOR ORDER CONFORMATION

HWID - □ - □

Number of detection point

- P16 : 1 to 16
- P32 : 17 to 32
- POV : Over 32

Enclosure of sensor

- E : Ex-type
- W : Weather proof

PRINCIPLE OF OPERATION

This system consists of the Main alarm panel / Repeat alarm panel on which the audible and visual alarms are activated and Electrode Type Level Switch operated by detecting the conductivity in the liquid and Intrinsically Safety barrier according to purpose or the position of the installation.

When the presence of water has reached the detecting point of level switch installed on the preset detection level in the cargo holder or other space, the electric signals which is activated on the level switches are transmitted to the main alarm panel provided with alarm unit, power supply unit and alarm buzzer, malfunction alarm as well as overriding device. At the same time, the audible and visual alarms are activated on the main alarm panel installed on the Navigation bridge and the repeat alarm panel installed on the bridge.

The overriding device for which the alarm can be deactivated or reactivated for the detector installed in the tank and holds used for carriage of water ballast will be provided on the alarm panel according to the SOLAS regulation XII/ 12.1.

An override visual indication should be continuously provided throughout deactivation of the water level detector for the hold or tanks used for carriage of water ballast. Where such an override function is provided, the override condition should be automatically reactivated after the hold or tank has been deballasted th a level below lowest level alarm indicator level.

When the fault is detected on water level detector, **the malfunction alarm** having visual and audible alarm the same as detection alarm on the main alarm panel should be activated to monitor continuously the system. The audible alarm should be capable of being muted but the visual indication should remain active until the malfunction is cleared.

The main power and standby power should be prepared on this system and if the main power is failed, the standby power should be supplied to the main alarm panel so as to monitor continuously.

When the main power is failed, the power failure alarm having audible and visual alarm should be operated. The water ingress detection system should be continuously operated while the ship is at sea.

The Electrode Type Level Switch installed in appointed space should be satisfied with the intrinsically safe type with the I.S barrier.

TECHNICAL SPECIFICATION

1. Main alarm panel

- Power supply : AC 110/220V 60Hz
- Stand-by power supply : DC 24V
- Number of detection point : No limits
- Accuracy of detecting : ±3mm
- Function :
 - visual alarm LED lamp for individual detection
 - audible main & pre-level alarm for individual detection
 - output signal for repeat alarm panel
 - overriding device, -common alarm buzzer
 - AC/DC power fail alarm & alarm reset
 - lamp test, -malfunction alarm
 - main power and standby power
 - navigation function, -time delay:0-99 seconds
 - dimming function, -flicker stop
- Mounting : wall or console mounting type

TECHNICAL SPECIFICATION

2. Repeat alarm panel

- Power supply : DC 24V
- Function :
 - visual alarm & LED lamp for individual detection
 - audible main & pre-level alarm for individual detection
 - common alarm buzzer
 - lamp test
 - dimming function
- Mounting : wall or console mounting type

3. Conductive electrode type Level switch

- Function :
 - When the electrodes is touched by an electrically conductive liquid, the low value A.C circuit detected on the electrodes is transmitted to the signal conditioning instrument on which the relay output contact signal is offered. This appropriate contact signal is transmitted to main alarm panel on which the audible and visual alarm is provided.
- Signal conditioning instrument(alarm unit) : I.S type, EEx ia IIC
- Operating voltage : 20~250VAC, 50/60 Hz,
- Input of response resistor : 1~200K Ω
- Relay output : 2A AC or 1A DC
- Enclose protection : IP 66/68
- Working pressure : 0~5 kg/ cm²
- Working temperature : -20 °C~80 °C
- Model number code system

16 CHANNELS ALARM UNIT



MODEL : AU-160D(W)

- No. of Channels : 16 channels
- Housing :
 - standard DIN cabinet for built-in mounting.
 - made of fiber glass reinforced Noryl.
 - front : 144 ×144mm, depth : 86mm
- Power supply
 - voltage : 24VDC(18~32VDC) or 85~264VAC
 - power consumption : 4.5W(24VDC)
- Input signals : Contact. NC or NO
- Time delays : 00~99 seconds (interval 1 sec.)
- Horn output
 - relay contact output : potential free SPDT.
- Accept horn
 - by means of push button on the front, or externally
- Accept flash
 - by means of push button on the front, or externally
- Test function : by pushing both accept push buttons
- Special function
 - override device, - malfunction alarm
 - main power and standby power
 - navigation function, - dimming function

